

DEPARTMENT OF THE ARMY TECHNICAL MANUAL

ORGANIZATIONAL, DS, GS,
AND DEPOT MAINTENANCE MANUAL

FREQUENCY SELECTIVE VOLTMETER

MODEL 128A

HEADQUARTERS, DEPARTMENT OF THE ARMY
APRIL 1967

WARNING

DANGEROUS VOLTAGES

EXIST IN THIS EQUIPMENT

Be careful when working on the power supplies and their circuits, or on the 115-volt ac line connections.

DON'T TAKE CHANCES

TECHNICAL MANUAL)
)
 NO. 11-6625-1519-15)

HEADQUARTERS
 DEPARTMENT OF THE ARMY
 WASHINGTON, D.C., 10 April 1962

Organizational, DB, GS, and

Depot Maintenance Manual

FREQUENCY SELECTIVE VOLTMETER MODEL 128A

SECTION	I	GENERAL	Page
	A-1	SCOPE	1-1
	A-2	INDEX CP PUBLICATIONS	1-1
	A-3	FORMS AND RECORDS	1-1
	A-4	PURPOSE	1-2
	A-5	DESCRIPTION	1-2
	A-6	SPECIFICATIONS	1-4
SECTION	II	OPERATION	
	A	CONTROLS AND INDICATORS	2-1
	B	OPERATIONAL CALIBRATION	2-3
	C	OPERATIONAL MEASUREMENTS	2-4
SECTION	III	CIRCUIT DESCRIPTION	
	A	SIGNAL CHANNEL	3-1
		1. Input Matching and Attenuator Circuits	3-1
		2. Preamplifier	3-1
		3. Input Low-Pass Filter	3-1
		4. First Mixer, First Modulator and First IF	3-2
		5. Second Mixer and Second Modulator	3-2
		6. Second IF Amplifier	3-2
		7. Meter Output Amplifier and Rectifier	3-3
		8. Audio Amplifier and Detector	3-3
		9. Carrier Reinsertion Oscillators	3-4
		10. Gain Reference Oscillator	3-4

		Page
B	MAIN TUNING AND FREQUENCY LOCK CIRCUITS	3-4
	1. Main Tuning Oscillator and Emitter Followers.....	3-4
	2. 100 KC Oscillator and Harmonic Generator.....	3-5
	3. Main Tuning Mixer.....	3-5
	4. Amplifier Detector, Low-Pass Filter and Main Lock Indicator.....	3-6
C	INCREMENTAL TUNING AND FREQUENCY LOCK CIRCUITS.....	3-8
	1. Incremental Tuning Oscillator and First LF Amplifier	3-8
	2. Second Oscillator	3-9
	3. Incremental Reference Oscillator and Mixer, and Second LF Amplifier	3-9
	4. Phase Discriminator and Low-Pass Filter	3-9
	5. Incremental Lock Indicator	3-10
D	POWER SUPPLY CIRCUITS	3-10
SECTION IV	MAINTENANCE	
A	GENERAL	4-1
B	ALIGNMENT AND CALIBRATION.....	4-3
	1. Test Equipment Required	4-3
	2. Power Supply	4-4
	3. Audio Circuits	4-4
	4. Output Amplifier	4-6
	5. Crystal Filter	4-7
	6. Second IF	4-7
	7. First IF	4-7
	8. First Modulator	4-8
	9. Second Modulator	4-8
	10. Input Filter	4-9
	11. Tracking and Locking, Main Tuning Oscillator	4-10
	12. Incremental Tuning Oscillator, Tracking and Locking	4-14
	13. Attenuator Calibration.....	4-20
	14. 110 KC Bandpass First IF	4-21
	15. General Checks	4-21
SECTION V	REPLACEABLE PARTS LIST	5-1
APPENDIX	A. BALANCED PROBE MODEL 128-PA	A-1
	(AUXILIARY EQUIPMENT)	
	B. EXPANDED SCALE METER MODEL 128-MA.....	B-1
	(AUXILIARY EQUIPMENT)	
	C. UNIVERSAL SPEAKER KIT	C-1
	(AUXILIARY EQUIPMENT)	

MODEL 128A

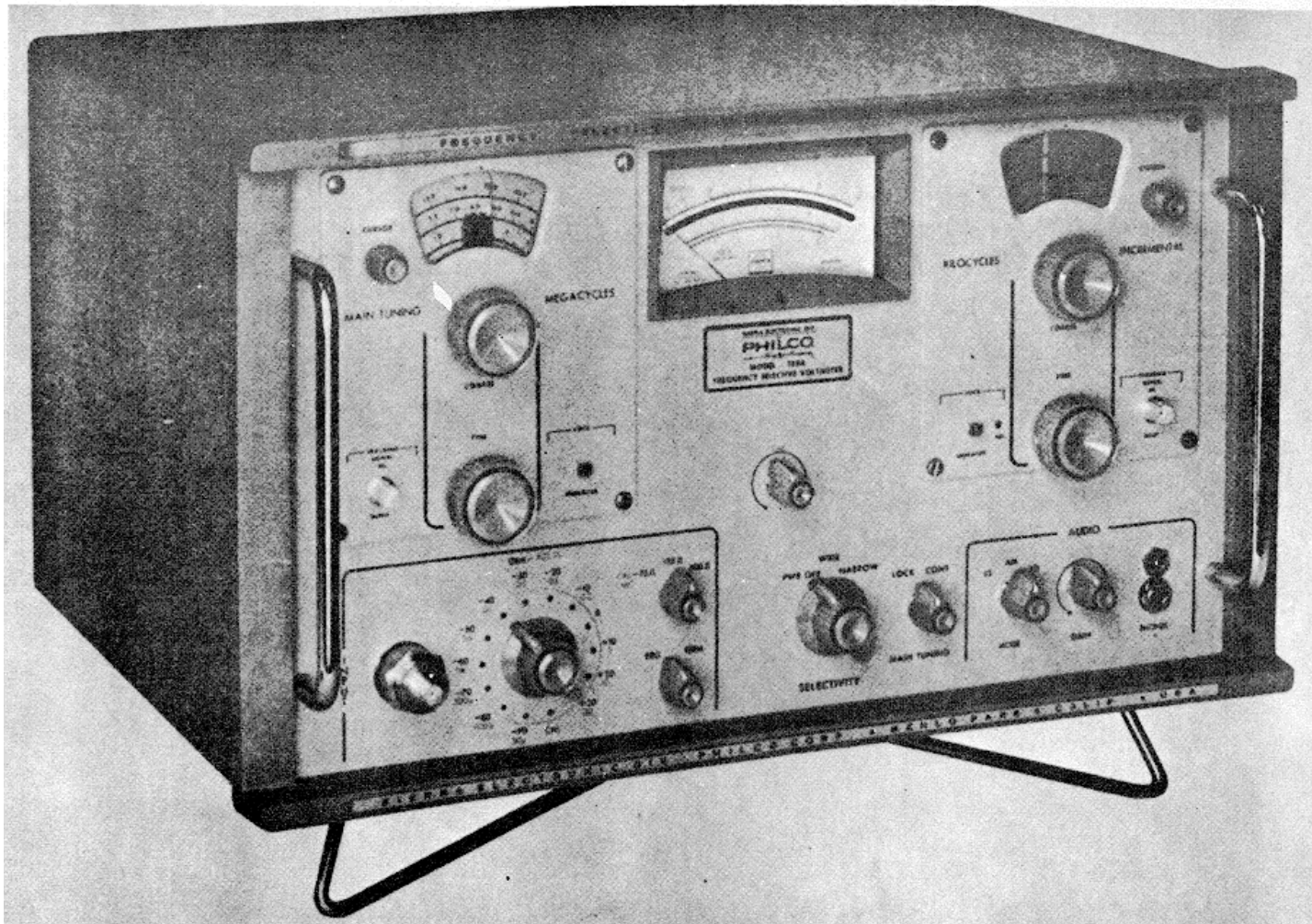

Figure 1-1. Model 128A Frequency Selective Voltmeter

This manual contains material reproduced by permission of Sierra Electronics Division of Philco Corp.

SECTION I.

GENERAL

A-1. SCOPE

a. This manual described Sierra Electronics (Federal Supply Code 94668) Frequency Selective Voltmeter Model 128A. It includes installation and operation instructions and covers operator's, organizational, direct support (DS), general support (GS), and depot maintenance. It also contains instructions for the use of Balanced Probe Model 128-PA, Expanded Scale Meter Model 128-MA, and Universal Speaker Kit.

b. To order this technical manual, requisition through pinpoint account number if assigned, otherwise through nearest Adjutant General Facilities.

A-2. INDEX OF PUBLICATIONS

Refer to the latest issue of DA Pam 310-4 to determine whether there are new editions, changes, or additional publications pertaining to the equipment. DA Pam 310-4 is an index of current technical manuals, technical bulletins, supply manuals (types 7, 8, and 9), supply bulletins, lubrication orders, and modification work orders that are available through publications supply channels. The index lists the individual parts (-10, -20, -35P, etc) and the latest changes to and revisions of each equipment publication.

A-3. FORMS AND RECORDS

a. Reports of Maintenance and Unsatisfactory Equipment. Use equipment forms and records in accordance with instructions in TM 38-750.

b. Report of Damaged or Improper Shipment. Fill out and forward DD Form 6 (Report of Damaged or Improper Shipment) as prescribed in AR 700-58 (Army), NAVSANDA Publication 378 (Navy), and AFR 71-4 (Air Force).

c. Reporting of Equipment Manual Improvements. Report of errors, omissions, and recommendations for improving this manual by the individual user is encouraged. Reports should be submitted on DA Form 2028 (Recommended Changes to DA Publications) and forwarded direct to Commanding General, U.S. Army Electronics Command, ATTN: AMSEL-MR-NMP-AD, Fort Monmouth, New Jersey 07703

MODEL 128A

Section I

A-4. PURPOSE

The Model 128A Frequency Selective Voltmeter is designed to measure a wide range of power levels and voltages with a high degree of accuracy over the frequency range of 10 kc to 15.1 mc.

It may be used to measure signal or carrier levels, harmonics, noise, crosstalk, or interfering signals in communications systems or communications receiving and transmitting equipment. It can also be synchronously tuned by a Tracking Signal Generator* when making a frequency run on a transmission line or circuit of a communications system. Either a narrow or wide bandwidth mode of operation is available in the instrument. Since the Voltmeter may be operated from either an ac or battery power source, it is readily adaptable for use in the field, at a communications terminal or in the laboratory.

A-5. DESCRIPTION

The Model 128A is a fully transistorized instrument employing modular circuit boards for component mounting. To provide adequate shielding for low level signals and stability of operation of the frequency generating sections, four aluminum castings are used to enclose a large part of the instrument circuitry. The castings are internally divided into compartments, each of which contains a circuit board assembly. This construction provides a high degree of isolation between circuits. The remainder of the circuit board assemblies are mounted on the chassis or the front panel. Shielded compartments are also used for these circuits where necessary.

The voltmeter may be tuned either continuously or frequency locked every 100 kc. Frequency lock is indicated by a relay operated panel lamp. Both aural (relay click) and visual (panel lamp) indication of the locked condition are thus furnished. For frequencies intermediate to the 100 kc points an Incremental Oscillator is used. The tuned frequency is the sum of the frequencies indicated by the Main Tuning and Incremental Tuning dials.

Input circuits of the Frequency Selective Voltmeter may be set for either the terminating or bridging mode. The termination mode provides a termination impedance to match either 75, 135 or 600 ohm lines or circuits. In the bridging mode the input impedance is sufficiently high, approximately 100,000 ohms, to insure a low bridging loss. Refer to Block Diagram Figure 1-2 for relationships of the various circuits.

*Sierra Model 351A

MODEL 128A

The Input Attenuator is adjustable in 10 db steps and is calibrated from -90 dbm to +30 dbm. The Attenuator is also calibrated in volts, the panel scale range being from 30 μ volts to 30 volts. To measure voltage the input must be set to the 600 ohm position.

Operational calibration of the instrument is provided by an internal Gain Reference oscillator. The output of this 1 mc crystal controlled oscillator is highly stabilized.

Bandwidth may be selected with a front panel control. Bandwidths of either 250 cps or 2500 cps are determined by crystal band-pass filters. Audio modulation on the signal may be continuously monitored through the wide band filter, the output of which is permanently connected to the input of the audio amplifier.

Monitoring of single sideband carrier systems is provided for by internal carrier reinsertion oscillators. Either sideband may be selected with a front panel switch.

A recorder output is available with an output of 0-200 μ a through a resistance of not more than 1200 ohms.

To provide for synchronous tuning of the Frequency Selective Voltmeter by means of a Tracking Signal Generator, input connectors are mounted on the dial panels of both the Main Tuning Oscillator and the Incremental Tuning Oscillator.

Dial drives of both oscillators have coarse and fine tuning controls. The dial calibrations are on a spiral scale and a cursor index automatically moves to indicate the proper reading point on the dial. This provides a long scale with widely spaced scale divisions.

Both tuning dials are fitted with a cursor adjustment as a front panel control. The index on the cursor may be set to the proper point on the dial scale using the internal one megacycle Gain Reference oscillator.

A-6. SPECIFICATIONS

FREQUENCY RANGE	10 kc to 15.1 mc
Main Tuning	
Locked, in 100 kc steps	0, 100, 200 kc. . 15 mc
Unlocked, continuous	0 to 15.1 mc
Incremental Tuning	
Continuous	-10 to 100 kc
Minimum Reading Increment	500 cycles
Accuracy, lock system actuated	20 ppm \pm 300 cycles

MODEL 128A

Section I

AUTOMATIC TRACKING TUNING

Required from external Tracking Signal Generator	
Main Tuning Frequency	21.1 mc to 36.1 mc
Incremental Tuning Frequency	200 kc to 310 kc

INPUT LEVEL RANGE

DBM (75D, 135D, 600Q)	-90 to \pm 32 dbm full scale
Minimum Reading Level	- 110 dbm
Voltage range (600 position only)	30 μ v to 30 volts full scale

MEASUREMENT ACCURACY

At reference frequency of 1 mc and 0 dbm level	\pm 0.2 db
--	--------------

Frequency response referred to 1 mc	
In Attenuator Positions -70 db to +30 db	
100 kc to 10 mc	\pm 0.2 db
10 kc to 15 mc	\pm 0.5 db

In Attenuator Positions -90 db to -80 db	
10 kc to 10 mc	\pm 0.5 db
10 kc to 15 mc	\pm 0.7 db

Attenuator Accuracy, Referenced to 0 dbm.	
Over the Frequency Range 100kc to 1mc	
-90db to +30db	\pm 0.1 db

Over the Frequency Range 10kc to 5mc	
-90db to +30db	\pm 0.2db

Over the Frequency Range 5mc to 10mc	
-70db to +20db	\pm 0.2db
-90db to +30db	\pm 0.3db

Over the Frequency Range 10mc to 15mc	
-70db to +20db	\pm 0.3db
-90db to +30db	\pm 0.8db

Variation in accuracy due to line voltage	
Variation of + 10%	0.1 db

Level Calibration Frequency	1 mc, Crystal Controlled
-----------------------------	--------------------------

MODEL 128A

Section I

INPUT IMPEDANCE

Bridging Mode	Unbalanced
Resistance	Greater than 100K Ω
Capacitance	
Attenuator Setting	
-60 db to +30 db	30 pf approximately
-90 db to -70 db	60 pf approximately
Terminating Mode	75 Ω , 135 Ω , 600 Ω
Reflection Coefficient	Less than 5%

SELECTIVITY

Bandwidths (Switch Selected)	2
Wide (Crystal Filter)	3100 cps (3 db points) 8000 cps (60 db points)
Narrow (Crystal Filter)	250 cps (3 db points) 1000 cps (60 db points)

INTERMEDIATE FREQUENCIES (Dual Conversion)

First IF	21.0 to 21.11 mc
Second IF	2.215 mc

SPURIOUS RESPONSES

Image Frequency Rejection (42 to 57 mc)	70 db down
Direct First IF Response (21.0 to 21.11 mc)	70 db down
Direct Second IF Response (2.215 mc)	80 db down
Residual Distortion Attenuation with an increase in Sensitivity of 50 db	Greater than 65 db

AUDIO

Audio Monitor	Continuous operation independent of bandwidth mode
Detection	
Amplitude Modulation	AM Detector
Single Sideband	Carrier Reinsertion combined AM detector
Output	Phones (600 Ω minimum impedance)

MODEL 128A

Section I

Recorder Output	
Load Impedance	No greater than 1200Ω
Output Level (Current)	0 to 200 μ a through load impedance
Output Connector	Telephone Jack
TEMPERATURE RANGE	+15°C to +40°C
POWER REQUIREMENT	
Line Power	115 volts AC ±10% 50-1000 cycles, 15VA
External Battery	28 volts DC 220 ma
OVERALL DIMENSIONS (Cabinet)	
Width	20 inches
Height	12 inches
Depth	14 inches
Rack Mounting (Cabinet Removed)	Standard 19 in. width
WEIGHT (In Cabinet)	50 pounds approximately

ACCESSORIES

A Balanced Probe, Model 128-PA, and an Expanded Scale Meter, Model 128-MA, are available as accessories to the Model 128A Selective Frequency Voltmeter. See the description and specifications of these instruments at the back of this Instruction Manual.

MODEL 128A

Section II

SECTION II.

OPERATION

A. CONTROLS AND INDICATORS

The front panel controls and indicators are listed below along with a brief indication of their use and the schematic reference number.

1. MAIN TUNING MEGACYCLES

Control or Indicator	Use	Schem. Ref. No.
COARSE	Coarse Adjustment MAIN TUNING	C1
FINE	Fine Adjustment MAIN TUNING	C1
CURSOR	Index Adjustment MAIN TUNING	
LOCK INDICATOR	Mode Indicator MAIN TUNING	DS1
TRACKING SIGNAL INPUT MC	Input for Synchronous Tuning	J2

2. INPUT

Control or Indicator	Use	Schem. Ref. No.
INPUT	GR Locking Input Connector	J1
DBM-VOLTS	Input Attenuator	S2
CAL - 75 Ω - 135 Ω - 600 Ω	Input Impedance Selector	S4
BRG TERM	Input Mode Selector	S3

MODEL 128A

Section II

3. FUNCTION

Control or Indicator	Use	Schem. Ref. No.
CAL	Adjustment for Operational Calibration	R34
OFF 2500 cps 250 cps	Instrument Power On-Off Bandwidth Selector	S1
LOCK CONT MAIN TUNING	MAIN TUNING Mode Selector	55

4. INCREMENTAL KILOCYCLES

Control or Indicator	Use	Schem. Ref. No.
COARSE	Coarse Adjustment INCREMENTAL Tuning	C1
FINE	Fine Adjustment INCREMENTAL Tuning	C1
CURSOR	Index Adjustment INCREMENTAL Tuning	
LOCK INDICATOR	Mode Indicator INCREMENTAL Tuning	DS2
TRACKING SIGNAL INPUT KC	Input for Synchronous Tuning	J3

5. AUDIO

Control or Indicator	Use	Schem. Ref. No.
MODE LS AM US	Detector Mode Selector	S6
GAIN	Audio Output Level Adjustment	R39
PHONES	Audio Output	J4

MODEL 128A

Section II

6. READOUT

Control or Indicator	Use	Schem. Ref. No.
Meter	Dbm or Volts	M1
RECORDER	Output for Recorder (on rear of chassis)	J5

B. OPERATIONAL CALIBRATION

Procedure for Operational Calibration sets the overall sensitivity of the voltmeter for all of its ranges. The highly stabilized Gain Reference Oscillator, the output of which is nominally within: ± 0.1 db under room ambient conditions, is used as the standard. (Level calibration must be carried out at the 1 mc frequency only.) Procedure follows:

1. Set INPUT DBM-VOLT attenuator to CAL. (Full clockwise rotation.)
2. Set INPUT Impedance selector to CAL-75Q.
3. Set FUNCTION Bandwidth selector to 250 cps.
4. Place FUNCTION MAIN TUNING Mode selector in LOCK position.
5. Set MAIN TUNING MEGACYCLES dial to 1 mc (LOCKED light will come on to indicated frequency locked condition.)
6. Set INCREMENTAL KILOCYCLES dial to 0 and carefully adjust tuning for maximum meter reading.
7. Adjust FUNCTION CAL control until meter reads 0 dbm.
8. If necessary set the cursor index directly over 0 mark on INCREMENTAL Tuning dial using CURSOR adjustment. If it is desired to set cursor on MAIN TUNING dial, set the dial, in the locked condition at 1 mc, or any harmonic, so that it is half way between the points at which it goes out of lock. With the CURSOR adjustment, set index directly under the 1 mc scale division mark, or at any of the harmonics of 1 mc.
9. If the Incremental Tuning Oscillator does not tend to stay in the locked condition, LOCK indicator light goes out, or if it does not return to the locked condition immediately after going out, change the ADJ control, just to the right of the INCREMENTAL LOCK indicator light, until the INCREMENTAL Tuning LOCK indicator light stays on. Several turns may be required. The ADJ control is a 26 turn continuous travel potentiometer which has been factory set at mid-range.

C. OPERATIONAL MEASUREMENTS

1. INPUT DBM-VOLTS Attenuator should be turned full clockwise to +30 dbm, or CAL, before connection is made to line or circuit, as a precautionary measure.
2. Perform Operational Calibration as outlined in B. above.
3. Set INPUT Impedance selector to the impedance of line or circuit to be checked, or to 600 Ω if voltage is to be measured.
4. Set INPUT Mode selector to BRG if measurement is to be made across a line or circuit already terminated. Set to TERM if the line must be terminated in its characteristic impedance.
5. If frequency of desired signal is known:
 - a. Set FUNCTION Bandwidth selector to 2500 cps.
 - b. Set FUNCTION MAIN TUNING Mode selector to LOCK.
 - c. Set INPUT DBM-VOLTS Attenuator to approximately the expected signal level.
 - d. Set INCREMENTAL Tuning dial to 0 kc.
 - e. Set the MAIN TUNING frequency dial to the nearest 100 kc lock point below the signal frequency.
 - f. Adjust INCREMENTAL Tuning for maximum meter reading.
 - g. Adjust Attenuator for a meter reading between -10 and +2 db.
 - h. Set FUNCTION Bandwidth selector to 250 cps and again adjust INCREMENTAL Tuning for maximum meter reading.
6. If frequency of signal to be measured is not known, or only approximately known:
 - a. Follow procedure steps a. through d. as given in paragraph 5. above, except that MAIN TUNING Mode selector should be set to CONT.

MODEL 128A

Section II

b. Rotate MAIN TUNING dial until an indication is seen on the meter. If necessary, set attenuator to progressively lower (greater sensitivity) levels and search for signal until a meter indication is obtained. Reduce sensitivity if meter "kick" seems large when passing over signal. A signal 20 db below the attenuator setting may be readily found with careful tuning.

c. Set MAIN TUNING Mode selector to LOCK and follow procedure e. through h. in paragraph 5. above.

7. Readout

a. DBM levels. (Assuming INPUT Impedance selector set to proper line impedance and line properly terminated.) Signal level is the algebraic sum of the attenuator db setting and the meter reading.

Example: Attenuator -20 dbm, Meter -4 dbm.
 $(-20) + (-4) = -24$ dbm

Example: Attenuator -20 dbm, Meter +1 dbm.
 $(-20) + (+1) = -19$ dbm

Example: Attenuator +20 dbm, Meter -4 dbm.
 $(+20) + (-4) = +16$ dbm

b. Voltage Levels. (Assuming INPUT Impedance selector is set to 600Q.) The meter has two voltage scales, 01 and 0-3. The attenuator range settings 100 μ , 1m, .01, .1, 1, 10 volts apply to the 0-1 scale. The range settings 30 μ , 300 μ , 3m, .03, .3, 3, 30 volts apply to the 0-3 scale. Each attenuator range setting refers to the maximum voltage that can be read on the appropriate meter scale.

Example: Attenuator 1m, Meter .8
 Read .8 millivolts, or 800 microvolts.

Example: Attenuator .03, Meter 1.5
 Read .015 volts

c. Frequency. The frequency to which the voltmeter is tuned is the sum of the MAIN TUNING dial indication in megacycles plus the INCREMENTAL Tuning dial indication in megacycles (kilocycles reading converted to megacycles).

Example: MAIN TUNING 11.3 mc, INCREMENTAL Tuning 34.5 kc.
 Frequency = 11.3 mc + .0345 mc = 11.3345 mc

MODEL 128A

Section II

8. Recorder Output

If a record of signal level changes on the line or circuit being monitored is desired, a recording device may be driven from the rear chassis jack marked RECORDER. The recording device will then be in series with the meter, but will not affect the meter reading as long as the recorder input resistance is 1200 ohms or less. Since the meter has a 200 microampere movement, approximately 200 microamperes through the recorder input will correspond to +2 dbm.

MODEL 128A

Section III

SECTION III.

CIRCUIT DESCRIPTION

A. SIGNAL CHANNEL

This division of the circuit description includes the circuits in the main signal path through the instrument from input to outputs. In addition, the Carrier Reinsertion oscillators and the Gain Reference oscillator are described. Refer to Schematic Diagram Figure 3-5 and to Block Diagram Figure 1-2.

1. Input Matching and Attenuator Circuits

a. Impedance and Level Adjustment. The proper load termination impedance to match 75 Ω , 135 Ω , and 600 Ω lines may be selected when INPUT Mode selector switch S3 is in the TERM position. The correct line impedance is selected by INPUT Impedance selector switch S4A. S4B-S4C sections of this switch function in either TERM or BRG Input Mode to select the proper level-adjusting network. Level to the preamplifier must be set to compensate for the different voltage levels corresponding to zero dbm across the various line impedances.

b. Attenuator. The input attenuator is a capacitive divider network which functions to keep the input signal level to the preamplifier within the limits required for the full scale range of the output meter. Thirteen attenuator positions in 10 db steps, selected by switch S2A-S2B, cover the range from -90 to +30 dbm. Attenuation is reduced to increase sensitivity for every step except for the -90 dbm position. In this position switch S2C operates a relay in the Output Amplifier circuit which increases the amplifier gain by 10 db to provide -90 dbm full scale sensitivity.

2. Preamplifier

A wide-band well stabilized preamplifier provides an impedance match between the high impedance of the input attenuator and the low impedance of the input filter without sacrificing gain. The amplifier consists of Q1, a Field Effect transistor amplifier, and a two stage amplifier, Q2, Q3, common-emitter connected. The emitter circuit of Q3 includes a high frequency adjustment.

3. Input Low-Pass Filter

Attenuation of all frequencies above the range of the instrument is accomplished by a four section low-pass filter. It is essentially flat over the pass-band range and cuts off at about 16 mc. The filter is made adjustable to provide for more precise overall alignment.

MODEL 128A

Section III

4. First Mixer, First Modulator and First IF

Frequency conversion from the signal frequency at the instrument input to the first intermediate frequency of 21.05 mc is carried out in the First Mixer. The signal at the input frequency is applied to the base of the mixer transistor Q1. The output of the Main Tuning Oscillator is applied to the First Modulator. The output of this balanced Modulator is connected across the emitter resistor of Mixer transistor Q1. Since the Modulator output is balanced to ground, the Main Tuning Oscillator frequency does not appear in the output, but the RF impedance of the modulator output varies at the Main Tuning Oscillator frequency rate. This varying impedance, connected across the emitter resistance of the Mixer transistor, causes the gain of Q1 to vary at this rate. The effect is to generate the sum and difference frequencies of the signal and Main Tuning Oscillator frequencies, but to practically eliminate the MAIN TUNING Oscillator frequency. The first IF circuit, which provides the load for the collector of the Mixer amplifier, is tuned to the difference frequency of 21.05 mc and thus only this frequency is amplified. The First IF circuit is a steep skirted band-pass filter with a very fiat response over a bandwidth of about 150 kc, centered on 21.05 mc. This bandwidth is necessary in order to accommodate signals 50 kc above and below the center frequency of the first IF stage, as the voltmeter is tuned between the 100 kc lock points with the Incremental Tuning Oscillator. Extreme flatness prevents change in gain over this bandwidth.

5. Second Mixer and Second Modulator

The Second Mixer and Modulator circuits operate in a manner similar to the First Mixer and Modulator. Input to the Second Modulator is from the Second Oscillator. First IF signal and Second Modulator output into the Second Mixer produce the second intermediate frequency of 2.215 mc. The Second Mixer has a single tuned circuit in the collector, tuned to the second intermediate frequency, as does the first stage of the Second IF amplifier to which the output of the Second Mixer is fed.

6. Second IF Amplifier

a. IF Buffer Amplifiers. After passing through the initial stage of the Second IF amplifier, the signal is applied to the two IF Buffer amplifiers. These common emitter stages not only separate the signal into two parallel channels, but also make it possible to provide the correct source impedance for the two crystal filters connected to their outputs.

b. Crystal Filters. The Crystal Filters, FL1 and FL2, determine the overall selectivity of the Frequency Selective Voltmeter. Both filters are centered on 2.215 mc. The narrow band filter FL2 has a bandwidth of 250 cycles, while the wide-band filter FL1 has a bandwidth of 2500 cycles.

c. Narrow and Wide Band Followers. Each crystal filter is followed by an emitter-follower stage. The amplifiers supply the narrow band or wide band signal to the Output Amplifier as either channel is selected by FUNCTION

MODEL 128A

Section III

Bandwidth selector switch S1B, S1C, S1D. A second emitter-follower, Q2, on the Wide Band module takes off the signal ahead of the switch and feeds it to the Audio Amplifier. Thus the signal is always connected through the Wide Band Follower to the Audio output circuits for audio monitoring purposes.

7. Meter Output Amplifiers and Rectifier

From either the Narrow or Wide Band Followers the signal goes to the Output Amplifier module. The stages in this amplifier operate at the second intermediate frequency. The first two, selective tuned, stages are separated from the rest by a shield placed across the module circuit board.

Gain in the first stage is increased 10 db when relay, K1 is closed, actuated by Attenuator switch, S2, when it is placed in the -90 dbm position, as noted in paragraph A.1.b. R2 and part of R4 are shunted out by the relay, increasing the voltage and changing the dc operating point to obtain the additional gain. To insure maximum gain stability, this stage is temperature stabilized by shunting part of the emitter resistor with a thermistor, RT1.

The gain of the second stage, Q2, is adjusted by front panel CAL control, R34, for operational calibration level adjustment. To provide for initial and maintenance calibration the gain of Q3 is varied by adjusting degeneration with the internally mounted control R19. This stage is broadly tuned to the second intermediate frequency.

The meter rectifier circuit is driven by the two stage, R-C coupled, feedback amplifier Q4-Q5. A large amount of negative feedback is used for stability and output linearity. The rectifier circuit is a modified bridge composed of CR1, CR2, C22, C23. Residual IF is filtered out of the meter circuit with L7-C24, L8-C25.

A closed circuit jack in series with the meter circuit is included to provide a recorder output. As long as the resistance introduced into the circuit by the recorder input is not more than 1200 ohms the meter reading will not be affected. This is possible since the feedback amplifier is in effect a constant current source.

8. Audio Amplifier and Detector

From the second Wide Band emitter-follower, Q2, the signal is fed to the Audio module where it is amplified at the second intermediate frequency in a selective tuned amplifier Q1. The output of Q1 is connected to Q2 which functions as either an AM or Sideband detector. An audio amplifier, Q3-Q4, raises the output of the detector to a level suitable for headphone operation. The signal is brought out to the PHONES jack through an emitter-follower, Q5, which makes possible the use of either high or low impedance phones. Audio level is adjusted by front panel AUDIO GAIN control, R39.

MODEL 128A

Section III

9. Carrier Reinsertion Oscillators (On Audio Circuit Board)

When the output of either of the carrier reinsertion oscillators is applied to the input of the detector, Q2, sideband modulation may be recovered. The oscillators are crystal controlled and each is followed by an emitter-follower to prevent excessive loading of the oscillator circuit. The oscillator frequencies are: one 1500 cycles above and one 1500 cycles below the second intermediate frequency. Either oscillator, or neither for AM, is selected by front panel switch S6 which controls the collector current supply to the oscillators.

10. Gain Reference Oscillator

The 1 mc crystal controlled oscillator, Q3, with the compound connected squaring amplifier, Q1, Q2, produces a rectangular signal suitable for the routine calibration of the Voltmeter. Output level is highly stable, variation being less than 0.1 db at normal ambient temperatures. Harmonics of the 1 mc frequency are accentuated in the network composed of L1-C1-R1 so that frequency check points are available over the full frequency range of the Voltmeter. Placing the INPUT Attenuator switch in the CAL position applies B- power to energize the oscillator.

NOTE

Level calibration must be carried out at the 1 mc frequency only.

B. MAIN TUNING AND FREQUENCY LOCK CIRCUITS

Nine circuit board modules mounted in compartments of the MAIN TUNING costing hold the components making up these circuits. See Schematic Diagram Figure 3-5.

1. Main Tuning Oscillator

The Main Tuning Oscillator uses a highly stabilized Colpitts circuit and is tuned by MAIN TUNING capacitor C1 over the range 21.1 mc to 36.1 mc.

a. Locked Mode. In this mode, MAIN TUNING Mode selector switch S5 in the LOCK position, the oscillator is locked on frequency every 100 kc over its full range by means of an error voltage applied to the varactor diode, CR1. The varactor diode is shunted across the oscillator tuning capacitor C1. The error voltage applied to the diode causes its effective capacity to vary in such a direction that the oscillator is maintained in a harmonic relationship with the 100 kc oscillator over a narrow tuning range around each 100 kc harmonic point. Generation of the error voltage is accomplished in the frequency lock circuit to be described in the following paragraphs, 2 through 4.

The Main Tuning Oscillator output passes to the input of two amplifiers, one located on the same circuit board and another separately mounted and designated as the Main Tuning Follower. Oscillator output is fed to this module through a relay, K1, which may be used to introduce an external signal into the Main Tuning Follower for

MODEL 128A

Section III

synchronous tuning operation. See below, sub-paragraph c. The Main Tuning Follower output goes through J8 to the input of the First Modulator for frequency conversion of the main signal to the first intermediate frequency. (Parallel connected jack, J9, is used in alignment procedures only.) The other output of the Main Tuning Oscillator passes through an amplifier, Q2, mounted on the Main Tuning Oscillator circuit board, to the Main Tuning Mixer.

b. Continuous Mode. When the MAIN TUNING Mode selector switch, S5, is placed in the CONT position, collector B- supply is disconnected from the 100 kc Oscillator and the Main Lock Indicator modules. At the same time a fixed bias is applied to the varactor diode, CR1, in the Main Tuning Oscillator circuit. Under these conditions the Voltmeter frequency can be tuned continuously over the full range with the MAIN TUNING Oscillator control, C1, and the frequency to which it is tuned will be indicated by the reading of the MAIN TUNING dial.

c. Tracking Signal Input. For synchronous tuning of the Frequency Selective Voltmeter a signal from an external Tracking Signal Generator is brought in through front panel connector, J2, marked TRACKING SIGNAL MC INPUT. This signal takes the place of the Main Tuning Oscillator output. Control DC to automatically operate relay K1, as well as the external signal, is carried by the center conductor of the connecting cable from the Tracking Signal Generator. When K1 is actuated the B- supply is disconnected from: the Main Tuning Oscillator, Main Tuning Mixer, 100 kc Oscillator and the Main Lock Indicator. At the same time the external signal is connected to the input of the Main Tuning Follower amplifier and fed to the First Modulator. (Refer also to paragraph, Tracking Signal Input Control, under Incremental Tuning Oscillator.) When these two Tracking Signal connections are made, tuning of the Voltmeter is completely controlled by, and is synchronous with, the external Tracking Signal Generator.

2. 100 kc Oscillator and Harmonic Generator

The crystal controlled 100 kc oscillator provides the highly accurate frequency which determines the 100 kc lock points for the Main Tuning Oscillator frequency dial settings. The oscillator, Q1, is connected in a Colpitts circuit. Output is a sine wave which is applied to the input of a Schmitt trigger, Q2-Q3. Since there is an inductance, L2, in the collector circuit of Q3, the Schmitt trigger output has a peaked waveform rich in high order harmonics, which is the desired condition. The oscillator output is isolated from the low impedance input of the Main Tuning Mixer by emitter-follower stage Q4.

3. Main Tuning Mixer

The peaked waveform output of the 100 kc Oscillator and Harmonic Generator is applied to the primary of the Main Tuning Mixer transformer T1 where, due to the resonant rise across the transformer inductance, it becomes still more sharply peaked. The negative swing is cut off by diode CR1, leaving a narrow positive going pulse as the waveform in the transformer primary.

MODEL 128A

Section III

The output of the Main Tuning Oscillator is applied to the center-tap of the secondary of T1. The combined inputs to T1 are applied to diodes CR2-CR3 which, since they conduct in only one direction, allow an output only for the duration of each 100 kc pulse.

The output to the Amplifier Detector is therefore a wave containing components of both the Main Tuning Oscillator frequency and the fundamental and harmonics of the 100 kc frequency. When the Main Tuning Oscillator frequency is exactly a harmonic of the 100 kc oscillator frequency, the output appears as a 100 kc pulse. See Figure 3-1, which shows the pulse after being rectified in the detector.

The 100 kc pulses are of constant amplitude provided the Main Tuning Oscillator frequency does not attempt to drift, or the Main Tuning Capacitor is not changed slightly. If either of these situations occur the pulses increase or decrease in amplitude, depending on the direction of attempted frequency change. This change in amplitude is due to change in phase relationships between the 100 kc pulse and the Main Tuning Oscillator signal, and is detected by the following circuits. Such a change generates an error voltage which is immediately applied to the varactor diode and changes its effective capacity slightly. The capacitance change is in the proper direction to maintain the Main Tuning Oscillator frequency in harmonic relation to the 100 kc signal. Thus in the locked condition the frequency of the Main Tuning Oscillator does not vary. Error voltage is developed by change in phase relationships only.

When the Main Tuning Oscillator is not in the locked condition the amplitude of the 100 kc pulses continuously vary. See Figure 3-2. The frequency of the envelope of these variations is the difference between the Main Tuning Oscillator frequency and the frequency of the nearest 100 kc harmonic, and thus will never be greater than 50 kc. In this condition the Main Lock Indicator light goes out.

4. Amplifier Detector, Low-Pass Filter and Main Lock Indicator

Output from the Main Tuning Mixer is passed through an emitter-follower, Q1, and a common-emitter amplifier, Q2, in the amplifier Detector module and applied to the base of the detector stage, Q3. The detector output is connected to the Low-Pass Filter, a two stage unit with a cutoff frequency of 50 kc.

When the 100 kc pulses out of the Mixer are of constant amplitude, the 100 kc modulation recovered by the detector is removed by the low-pass filter, and the filter output is a dc voltage which is proportional to average pulse amplitude. A change in average pulse amplitude will therefore cause a change in dc voltage. This is the error voltage that is applied to the varactor diode to maintain the Main Tuning Oscillator on frequency, in the locked condition. See Figure 3-3.

MODEL 128A Section III

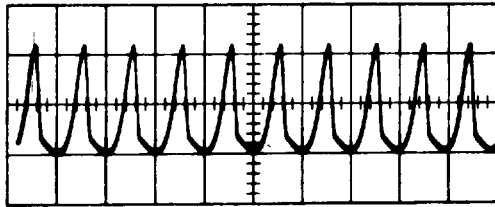

Hor: 10 μ s/cm

Figure 3-1. 100 kc Pulses, Locked Waveform, Amplifier Detector Output

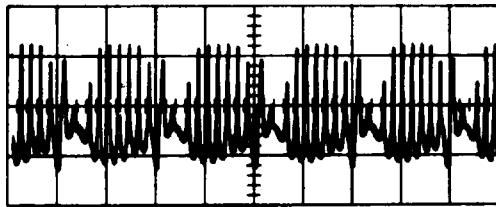

Hor: 50 μ s/cm

Figure 3-2. 100 kc Pulses, Unlocked Waveform, Amplifier Detector Output

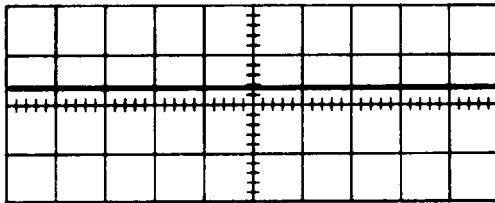

Hor: 50 μ s/cm

Figure 3-3. Locked Waveform, Main Tuning Low Pass Filter Output

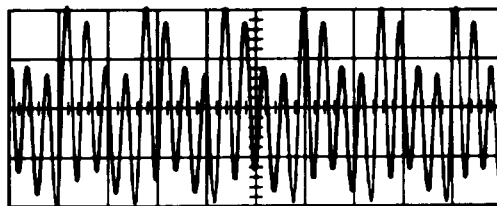

Hor: 50 μ s/cm

Figure 3-4. Unlocked Waveform, Main Tuning Low Pass Filter Output

MODEL 128A

Section III

When the pulses are continuously varying in amplitude, the unlocked condition, the modulation envelope is detected. Since the envelope frequency is always less than 50 kc, as noted above, this alternating signal passes through the low-pass filter. See Figure 3-4.

The alternating signal out of the low-pass filter is amplified by Q1 in the Main Lock Indicator module and applied to the input of the Schmitt trigger Q2-Q3. This circuit is adjusted to trigger on at a very low ac voltage so that Schmitt-trigger output occurs as soon as the Main Tuning Oscillator lock control is lost. The trigger output flows through relay K1, causing it to open and the LOCKED indicator light to go out.

The same alternating voltage is applied to the varactor diode, but because it fluctuates rapidly it will not cause the oscillator to lock in. When the Main Tuning Oscillator is adjusted so that it is close to a 100 kc harmonic frequency and the alternating voltage frequency is reduced sufficiently, a point is reached at which the lock circuits take control; the low pass filter output becomes dc, the Schmitt trigger in the Main Lock Indicator module is cut off and the LOCKED indicator light comes on.

C. INCREMENTAL TUNING AND FREQUENCY LOCK CIRCUITS

Eight circuit board assemblies make up the Incremental Tuning and Frequency lock circuits. Each board is mounted in a separate compartment of the INCREMENTAL tuning casting which sets on the right side of the instrument. See Schematic Diagram Figure 3-5.

1. Incremental Tuning Oscillator and First LF Amplifier

Adjustment of the Frequency Selective Voltmeter to frequencies between the 100 kc harmonic points selected by the Main Tuning Oscillator control is accomplished with the Incremental Tuning Oscillator. This is a very stable Clapp oscillator covering the frequency range of 200 kc to 310 kc, tuned with front panel mounted capacitor C1. Tuning dial calibration is from -10 to 0 to 100 kc, providing a range that overlaps the 100 kc lock points of the Main Tuning Oscillator.

Oscillator output is amplified in the common-emitter stage Q1, of the First LF Amplifier module. Output then passes through the contacts of relay K1, through two emitter-follower stages, Q2-Q3, to the primary of T1 in the Phase Discriminator module. The power gain of the emitter-follower stages furnishes the signal level required in the primary of T1.

Tracking Signal Generator control for synchronous tuning is fed in through J3 and relay K1. When the connection is made from the external Tracking Signal Generator, dc control voltage carried by the interconnecting cable actuates K1. At this time the Incremental Tuning Oscillator output is disconnected from the circuit, and the Tracking Signal Generator signal is connected to emitter-follower Q2 in its place. See also paragraph B.1.c. above.

MODEL 128A

Section III

2. Second Oscillator

To make the frequency conversion from the First IF band of 21.000-21.110 mc to the second IF of 2.215 mc, the Second Oscillator tunes over the range of 18.785 mc to 18.895 mc. Tuning is accomplished solely by means of varactor diode CR1. This is a voltage variable capacitor connected in the tuned circuit of the Second Oscillator. It functions in a similar manner to the varactor diode in the Main Tuning Oscillator. Adjusting the Incremental Tuning Oscillator causes the voltage across CR1 to be changed by means of the circuits to be described shortly, providing exact control of the Second Oscillator frequency.

Output of Second Oscillator, Q1, is applied to the base of each of two emitter-follower amplifiers, Q2-Q3, both mounted on the Second Oscillator module circuit board. The output of Q2 is fed through J20 to the input of the Second Modulator. (Parallel jack, J19, is provided for use in alignment procedures.) From the output of Q3 the signal is applied to the center tap of the mixer transformer in the Incremental Reference Oscillator and Mixer module through common-emitter isolation amplifier, Q2.

3. Incremental Reference Oscillator and Mixer, and Second LF Amplifier

Control of the Second Oscillator by the Incremental Tuning Oscillator requires the intermediate step in frequency generation provided by the Incremental Reference Oscillator. This is a crystal controlled Colpitts oscillator operating on a frequency of 18.585 mc.

The oscillator output is fed into the primary of mixer transformer T1. A signal from the Second Oscillator is fed into the center top of the secondary of this same transformer through isolation amplifier Q2. These signals are mixed in the output circuit to form a difference frequency which is taken out at the arm of potentiometer, R7. The difference frequency, determined by the tuning of the Second Oscillator, covers the range of 200 to 310 kc.

Mixer output goes to the Second LF Amplifier, made up of a common-emitter and an emitter-follower stage, where the signal is raised to a suitable level for application to the Phase Discriminator.

4. Phase Discriminator and Low-Pass Filter

In this circuit the 200-310 kc frequency of the Incremental Tuning Oscillator is fed into the primary of T1. The 200-310 kc output of the Incremental Reference Oscillator Mixer is fed into the primary of T2. The output connections of the secondaries of these transformers, the diodes CR1-CR2 and associated components form the phase discriminator circuit. When the two input signals are the same frequency, the output appears as a half-wave rectified signal. This signal passes to the Low-Pass Filter. Since the cutoff frequency of this filter is 125 kc, the signal frequency components are filtered out and the output is a dc voltage proportional to the average amplitude of the rectified signal components. As long as the two signals are of the same frequency, the average level of the signal components will change as phase relationships between the two input signals change.

MODEL 128A

Section III

The dc voltage output of the Low-Pass Filter is connected to the varactor diode in the Second Oscillator and controls the frequency of this oscillator. Control is sufficient to keep the Second Oscillator continuously locked to the Incremental Tuning Oscillator over its full range of tuning. Since the Second Oscillator output frequency when mixed with the output of the Incremental Reference Oscillator must generate an output that is the same frequency as that of the Incremental Tuning Oscillator for locking to take place and continue, the control of the Incremental Tuning Oscillator over the Second Oscillator is exact. Therefore, the oscillators are in the phase locked condition for every setting of the Incremental Tuning Oscillator dial.

5. Incremental Lock Indicator

When the input signals to the Phase Discriminator are not exactly the same frequency, a beat frequency output is produced. This beat will be low in frequency and cannot be greater than 110 kc in the extreme case (the difference between 200 and 310 kc), so it readily passes through the low-pass filter to actuate the Incremental Lock Indicator. As in the Main Lock Indicator, any alternating signal at the input is amplified and actuates the Schmitt trigger, causing the contacts of relay K1 to open and the LOCKED indicator light to go out.

The unlocked condition normally will only occur for a short period after the instrument is turned on, or if the Incremental Tuning Oscillator dial is rotated very rapidly. This unlocked condition will be only momentary since the lock circuit is very rapid in its action. Diodes CR3-CR4 and associated circuitry on the Phase Discriminator Module aid in the rapid take-over of control for the locked condition.

To provide for any possible change in locking characteristics with passage of time, the LOCK ADJ control, R1, a 26-turn continuous travel potentiometer, located just to the right of the INCREMENTAL LOCK indicator light on the front panel, is provided. The control adjusts a fixed bias on the varactor diode, CR1, in the Second Oscillator circuit to restore the Second Oscillator frequency to the mean of the locking range. Schematically the potentiometer is connected to the Incremental Tuning Oscillator circuit board.

D. POWER SUPPLY CIRCUITS

A 16 volt regulated supply provides power for the voltmeter circuits. Input to the supply may be either 115 volts ac or 28 volts dc. The supply is mounted on one circuit board and consists of a solid state rectifier and filter, a series regulator circuit and a relay for ac-dc power supply switch elimination.

MODEL 128A**Section III**

The solid state rectifier is transformer coupled to the ac line. Rectifier output is connected to the series regulator through the contacts of relay K1. K1 is connected directly across the ac line and is closed to connect the rectifier output to the series regulator only when the instrument is plugged into a 115 volt ac supply. Otherwise the series regulator is connected to the battery input jacks J6-J7 through diode CR6. This relay connection will not allow both battery and ac supplies to be connected to the series regulator at the same time. Diode CR6 prevents the inadvertent application of battery voltage of the wrong polarity.

When using a battery supply negative polarity must always be connected to J7.

MODEL 128A

**SECTION IV.
MAINTENANCE**

A. GENERAL

Since the Model 128A is all solid state and is a conservatively designed instrument, it may be expected to provide many hours of trouble free operation.

If trouble should occur, probable expected order of trouble is: incandescent panel lamp failure, development of noise in most frequently used controls, power supply diode failure, increased leakage or complete failure of transistors, increased leakage of capacitors and change in value of resistors.

If trouble shooting becomes necessary, a good understanding of circuit operation and signal flow paths as outlined in the Theory of Operation, Section III, and the Schematic Diagram, Figure 3-5, will aid greatly in tracing the cause of the trouble.

Signal level voltages at numerous points along the signal flow path are given in the Signal Levels Block Diagram Figure 4-1. Voltages indicate the rms signal level to be introduced at that point to obtain a 0 db reading on the meter of the 128A instrument. The frequency of the signal will be the frequency that normally occurs at that point as indicated on the Block Diagram. Signal levels may be expected to vary somewhat in different instruments.

Wave forms, frequency and amplitude of the Frequency Lock circuits are given in Figures 4-4, 4-7, 4-8.

Location of modules and calibration adjustment points is given in Figures 4-2, 4-3, 4-5, 4-6, 4-9, 4-10.

The circuit boards have a number screened on the component side. This is the same number as that which appears within the dashed-line box indicating the module on the schematic diagram. The name of the module is etched on the foil side of the circuit boards. This name also is the same as that appearing on the Schematic Diagram.

The following general outline of trouble tracing is suggested:

1. Make sure all cable connectors are properly connected and screwed up snugly.
2. Check power supply output voltage. It should be approximately -16 volts dc.
3. Using a wideband oscilloscope (such as a Tektronix 543) check for proper output at J8, Main Tuning

MODEL 128A

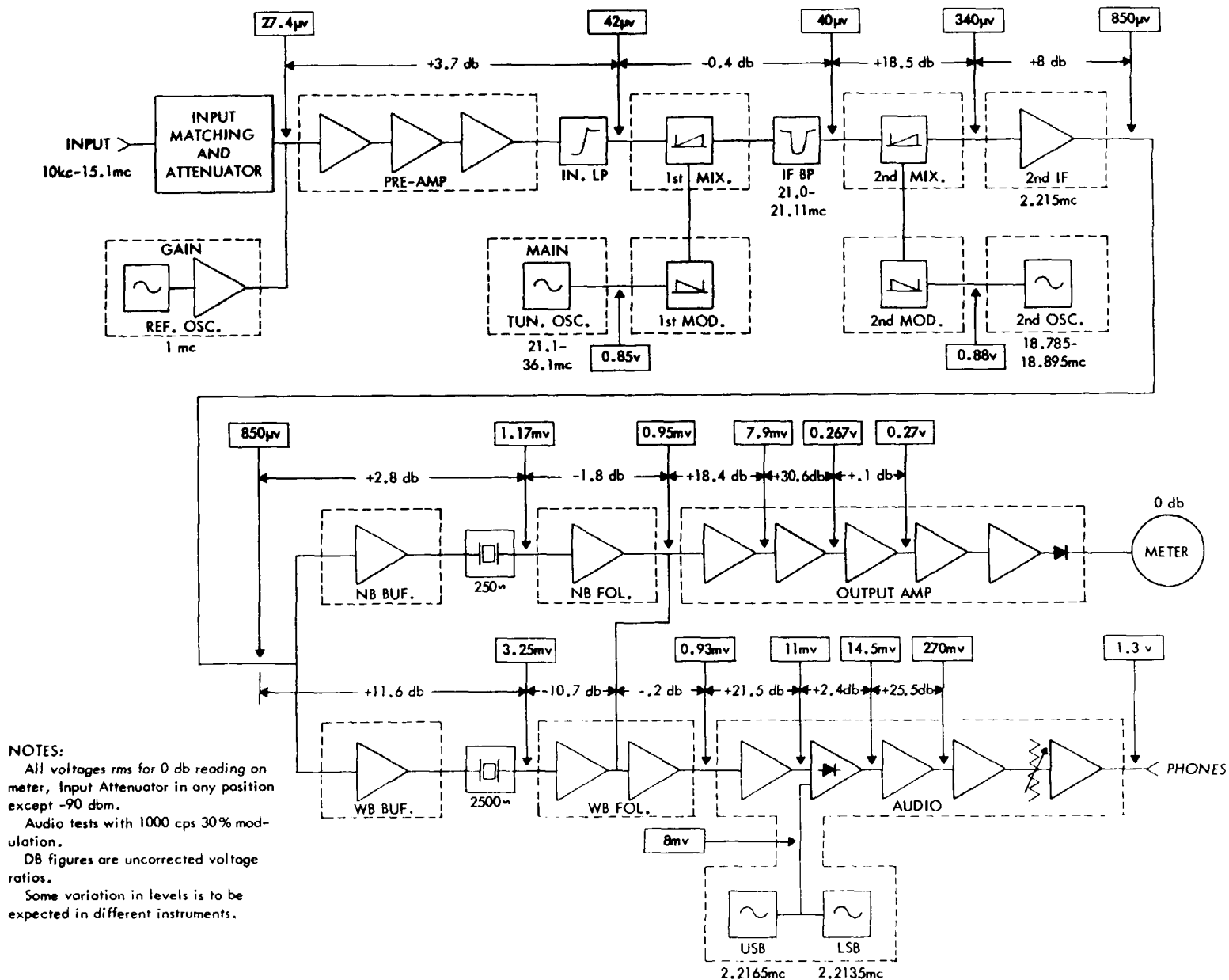

NOTES:
 All voltages rms for 0 db reading on meter, Input Attenuator in any position except -90 dbm.
 Audio tests with 1000 cps 30% modulation.
 DB figures are uncorrected voltage ratios.
 Some variation in levels is to be expected in different instruments.

Figure 4-1. Signal Levels, Block Diagram

MODEL 128A

Follower, and at J20, Second Oscillator. This check will localize the trouble to either of the Tuning modules or to the signal flow path modules.

4. If the output of either Tuning module is improper as to frequency, waveform or amplitude, Figure 4-4a or 4-7a, the various module circuits should be carefully checked using the waveforms of Figures 4-4, 4-7, and 4-8 as a guide to proper operation.

5. If tuning and module output waveforms appear to be correct, the trouble is probably in the signal flow path modules. Refer to Figure 4-1 and introduce a signal of the proper amplitude and frequency at a point midway along the signal path. For example: a 2.215 mc, 340 microvolt signal into the input of the second IF amplifier. (Tuning modules must be connected and operating for these tests.)

6. If the panel meter reads approximately 0 db, select a point farther back toward the Input to introduce the next test signal.

7. If panel meter reading varies widely from 0 db, or no reading is obtained for the test of paragraph 5 above, select a point closer to the meter and introduce the proper test signal.

8. Follow the above procedure until faulty module is bracketed between two closely spaced test points.

Note that the attenuator must not be placed in the -90 dbm position for these tests. In this position an extra 10 db gain is introduced into the Output Amplifier.

9. When the faulty module has been located, check the signal flow through that module, and check individual components as necessary.

B. ALIGNMENT AND CALIBRATION

No change in adjustments should be made unless the required test equipment is available and complete alignment procedures may be carried out. In this procedure the instrument being aligned will be referred to as "the voltmeter".

1. Test Equipment Required (Items Listed or Equivalent)
 - a. Signal Generator, HP 606A
 - b. Clip-on Milliammeter, HP 428B
 - c. DC Vacuum Tube Voltmeter, HP 412A
 - d. AC Vacuum Tube Voltmeter, HP 400L
 - e. VHF Attenuator, HP 355B
 - f. Frequency Counter and Converter, HP 524C and 525A
 - g. Oscilloscope, Tektronix 543
 - h. 50 ohm Coaxial Termination Load, Sierra Model 160-1

MODEL 128A

2. Power Supply

- a. Connect the voltmeter to a variable 115 volt AC source. Connect the DC VTVM to TP2 on the bottom side of the chassis.
- b. Adjust the AC source to 115 volts and switch the voltmeter on.
- c. DC VTVM should read -16.0 volts. If not, adjust R2 in the power supply until a reading of -16.0 volts is obtained.
- d. Connect the Clip-On Milliammeter to the violet wire between the power supply PCB and F2. Full load DC current should be approximately 230 ma.
- e. Vary the AC source voltage between 105V and 125V. There should be no change in the DC VTVM reading. A change would indicate voltage regulator trouble.
- f. Connect the DC VTVM to the external battery input jacks, J6-J7. Short CR6 in the power supply with a clip lead and short the three relay contact springs (K1 in power supply) together. The DC VTVM should read -16 volts. Remove the clip lead from CR6 while leaving the relay contacts shorted and observe that voltage is removed from J6-J7. This checks proper operation of CR6 which is to prevent wrong polarity connection of an external battery supply.

3. Audio Circuits

It is necessary to remove the Audio cover shield to gain access to all adjustments on the Audio module.

- a. Disconnect J23, input to IF Buffers and P30 and P31, the B- connections to the tuning oscillators.
- b. Connect the Frequency Counter to the vertical amplifier output of the Oscilloscope.
- c. Connect the vertical input of the Oscilloscope to the junction of C20-R28 on the Audio module and turn the Detector Mode switch to LS.
- d. Adjust L3 on the Audio module for maximum indication on the Oscilloscope (approximately 2.0 volts p-p) and check that the frequency reading on the counter is $2.2135 \text{ mc} \pm 110 \text{ cps}$.
- e. Connect the Oscilloscope to the junction of C26-R38 on the Audio module and turn the Detector Mode switch to US.

MODEL 128A

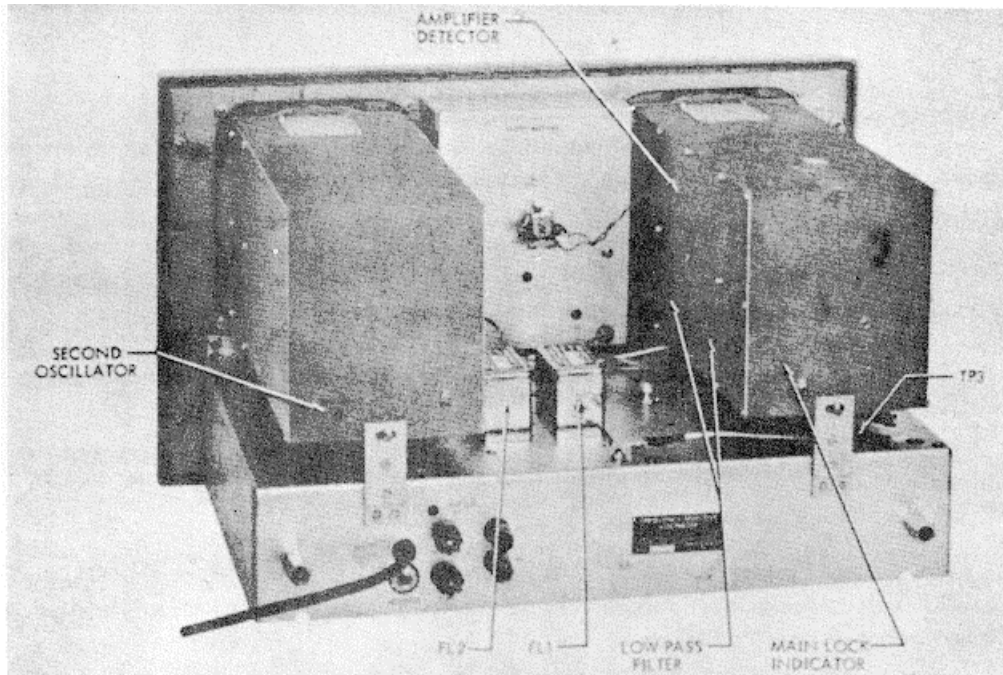

Figure 4-2. Rear View, Module Location

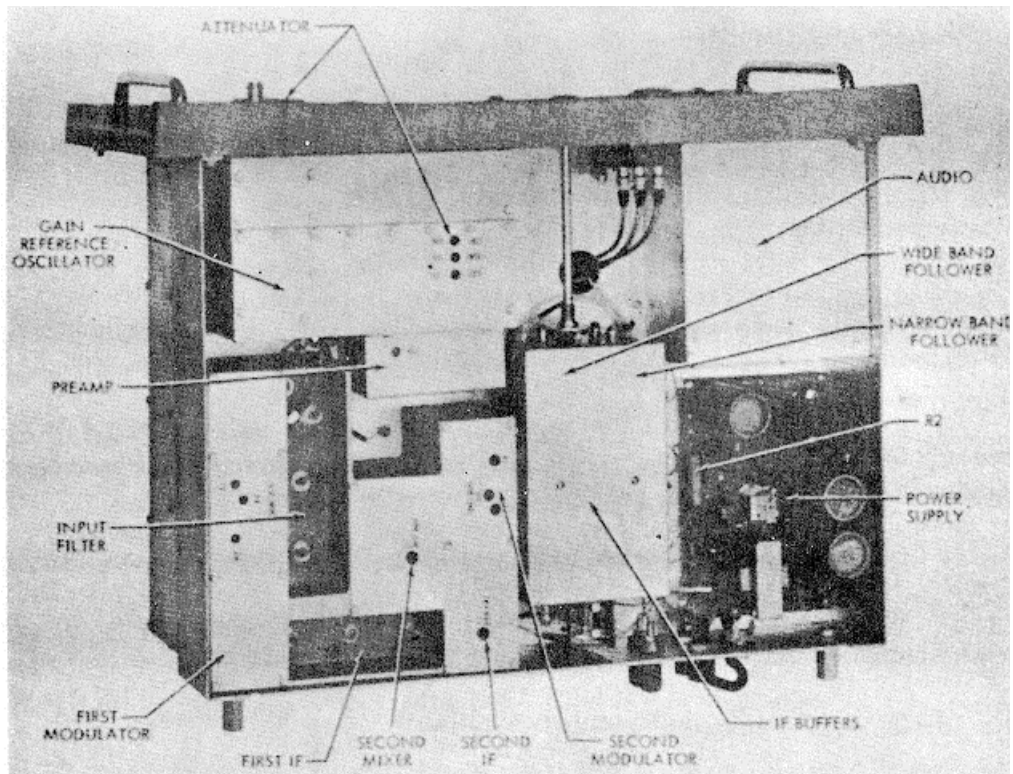

Figure 4-3. Bottom View, Module Location

MODEL 128A

- f. Adjust L4 for maximum indication on the Oscilloscope (approximately 2.0 volts p-p) and check that the frequency reading on the counter is $2.2165 \text{ mc} \pm 110 \text{ cps}$.
- g. Connect the Signal Generator to J28 (input to the audio module) and the Oscilloscope to the base of Q2 on the Audio module. Tune the Signal Generator to 2.215 mc and the output to approximately $700 \mu\text{v}$.
- h. Turn the Detector Mode switch to AM and adjust L1 for maximum indication on the Oscilloscope.
- i. Modulate the Signal Generator signal 30% with the internal 1 kc frequency.
- j. Connect the AC VTVM to the output jack J4 and turn the Audio Gain control R39 fully clockwise. Output voltage for each setting of the Detector Mode switch should be approximately as follows:

AM - 3.0 volts modulated
LS - 3.0 volts unmodulated
US - 3.0 volts unmodulated

4. Output Amplifier

- a. Connect the Signal Generator to J27 (input to the output amplifier module), tune to 2.215 mc and set the output to approximately $500 \mu\text{v}$.
- b. Set the voltmeter front panel CAL control and R 19 on the output amplifier PCB to center position.
- c. Set the voltmeter Attenuator switch to -90 db, 75 ohm/TERM. Check that the relay K1 on the output amplifier PCB operates as Attenuator switch is moved from -80 db to -90 db position.
- d. Adjust L1 and L2 in the output amplifier for maximum deflection on the voltmeter panel meter, approximately 0 db. Overall gain with R19 and CAL controls centered and with Attenuator in the -90 db position should be 55 to 60 db.
- e. Set the CAL control (or Signal Generator output) for an exact 0 db reading.
- f. Switch the voltmeter Attenuator to the -80 db position and raise the Signal Generator output 10 db.
- g. Adjust R4 on the output amplifier PCB for a 0 db reading.
- h. Reconnect cable to J27.

MODEL 128A

5. Crystal Filter

- a. Connect the Signal Generator to J23 (input to the IF Buffers), tune to 2.215 mc and set output to approximately 500 μv .
- b. Set the voltmeter front panel Bandwidth switch to 2500 ~ and set the CAL control (or Signal Generator output) for an exact 0 db reading on the voltmeter panel meter.
- c. Turn Bandwidth switch to 250 ~ and adjust R11 on the IF Buffer PCB for a 0 db reading.
- d. Reconnect cable to J23.

6. Second IF

- a. Remove the T shaped cover from the IF casting. Tune the Signal Generator to 2.215 mc and set the output to approximately 30 μv .
- b. Using a 0.1 μf capacitor connect the Signal Generator to the input of the second mixer (feed-through insulator with orange wire).
- c. Set the voltmeter Bandwidth switch to 2500 ~.
- d. Adjust L1 in the second IF and L1 in the second mixer for maximum deflection on the voltmeter panel meter.
- e. Replace IF cover.

7. First IF

- a. Remove the rectangular cover from the IF casting. Loosen the locknuts on LS, L6, L7 on the First IF.
- b. Connect the B- plug P31 to J31 to provide B- for the Incremental Tuning oscillator. Set Incremental Tuning dial to 0.0 position.
- c. Tune the Signal Generator to 21.1 mc set to approximately 50 μv output, and connect to the First Modulator output at the 220 ohm feed-through resistor R7. Adjust Signal Generator output for a mid-scale reading on the voltmeter panel meter.
- d. Adjust L5, L6, L7 in the First IF for maximum deflection on the voltmeter panel meter, decreasing the Signal Generator output to keep the meter on scale if necessary. Signal Generator output should be approximately 25 μv for a 0 db panel meter reading when amplifier is properly aligned.

MODEL 128A

e. Reconnect the B- connection P30 to the main tuning oscillator. Set the Main Tuning dial to 1.0 mc. Set the voltmeter input Attenuator to -80 db, 75 ohm/TERM and set the Bandwidth switch to 250 ~.

f. Tune the Signal Generator to 1 mc, set the output to approximately -80 db and connect to the voltmeter input.

g. Readjust all inductances for maximum panel meter deflection, L5, L6, L7 in the First IF, L1 in the Second Mixer, L1 in the Second IF, L1, L2 in the output amplifier.

h. Connect the AC VTVM to the audio output jack J4, set Detector Mode switch to either US or LS and tune L1 in the audio amplifier to maximum indication on the AC VTVM.

8. First Modulator

a. Tune the Signal Generator to 50 kc, set the output to 0 db and connect to the input of the voltmeter.

b. Set the voltmeter Attenuator to 0 db, 75 ohm/BRG and the Bandwidth switch to 250 ~. Set the Main Tuning dial to 0.0 mc and tune the Incremental Tuning oscillator to the 50 kc signal. Voltmeter in Locked condition.

c. Adjust R3, C2, C4 in the First Modulator for maximum voltmeter panel meter deflection.

d. Remove the Signal Generator signal, switch to 2500 ~ and tune the Incremental Tuning oscillator toward 0 kc until the meter reads almost full scale.

e. Adjust R3, C2, C4 in the First Modulator to minimize meter reading while tuning the incremental oscillator further toward 0 until an adjustment minimum is reached. A 3 kc setting on the incremental oscillator should cause a meter reading of less than -10 db (with output of preamplifier disconnected).

9. Second Modulator

a. Set the voltmeter Bandwidth switch to 2500 ~ and the Main Tuning dial to 0.1 mc. Set the input Attenuator to -90 db, 75 ohm/TERM.

b. Tune the Incremental Tuning oscillator slowly from 0 to 100 kc. Notice the spurious responses at 23, 54, 78 and 100 kc.

c. With first modulator detuned, adjust C100, C14, R7, in the Incremental Reference Mixer to minimize the spurious responses noted above. (Main Tuning set at 0.1 mc and Incremental Tuning from 100 kc to 0.) After adjustment repeat para. 8.

MODEL 128A

d. Set the Main Tuning dial to 0.3 mc and adjust R3, C2, C4 in the Second Modulator to reduce the spurious responses at 23, 54 and 78 kc to below -115 db on the panel meter.

e. Set the Main Tuning dial to 0.1 mc and check for a spurious response between 53 and 57 kc. Readjust R3, C2, C4 in the First Modulator slightly to reduce this response to below -115 db.

f. Set the Bandwidth switch to 250~. Tune the incremental tuning oscillator slowly from 0 to 100 kc. All spurious responses should be below -115 db.

g. If a spurious signal shows up around the 50 kc point on the Incremental Tuning dial in the wideband (2500~) position but not in the narrow band (250~) position, readjust the first modulator until this spurious signal disappears. If First Modulator is properly aligned, this spurious will not appear.

h. Check for spurious responses throughout range of MAIN TUNING oscillator in the Unlocked condition. If any spurious responses are present, replace First Mixer transistor and repeat para. 8.

10. Input Filter

a. Tune the Signal Generator to 7.8 mc, set output to -91.75 db, terminate with 50Ω coaxial termination load and connect to the voltmeter input.

b. Set the voltmeter Attenuator to -90 db. 75 ohm/BRG and tune in the 7.8 mc signal. Adjust the CAL control for a panel meter reading of 0 db.

c. Tune the Signal Generator to 50 mc, raise the output by 70 db and adjust L1 in the Input Low-pass Filter for a minimum reading on the voltmeter panel meter.

d. Tune the Signal Generator to 21.1 mc and adjust L2 in the Input Low-pass Filter for a minimum reading on the panel meter.

e. Minimum adjustment value in both step c. and d. should be below the specified attenuation level (70 db), (meter reading below 0 db). If not see below.

f. If attenuation is greater than 70 db (meter reads below 0 db) tune L4 in the Input Low-pass Filter in the inward direction. If attenuation is less than 70 db (meter reads above 0 db) tune L4 in the outward direction. Recheck steps c. and d. above and retune L4 until the desired -70 db level is reached. Recheck and retune L1 if necessary.

g. Tune the Signal Generator to 15.1 mc and adjust L3 in the Input Low-pass Filter for maximum reading on the panel meter.

MODEL 128A

11. Tracking and Locking, Main Tuning Oscillator

If the Main Tuning adjustments are badly out of line, follow the procedure given in paragraph a. If normal service realignment check is to be performed, start procedure with paragraph b. For module location and waveforms refer to Figures 4-4, 4-5, 4-6.

a. Adjustments, Main Tuning Oscillator

Additional test equipment required for these adjustments:

RF Microvoltmeter with High Impedance Probe,
Millivac MV 28B or equivalent.

RF Oscilloscope, Tektronix 581 or equivalent.

(1) Attach the probe of the RF Oscilloscope to J9. .With plates of the Main Tuning capacitor fully meshed, frequency about 21 mc, the voltage should be 2.7 volts p-p. See Figure 4-4a.

(2) Set Main Tuning Mode to CONT. Set Cursor Index to midrange.

(3) Connect the Frequency Counter with an adapter cable to J9.

(4) Set the tuning dial to 0.0 mc and check that tuning capacitor is 1/16" from full mesh.

(5) Adjust L1 on the Main Tuning oscillator until the counter reads approximately 21.1 mc. (Tuning dial at 0.0 mc.)

(6) Rotate the tuning dial to 15.0 mc and adjust C8 until the counter reads approximately 36.1 mc.

(7) Repeat steps (5) and (6) until counter readings are within *10 kc.

(8) Set Main Tuning Mode switch to Lock.

(9) Attach probe of Oscilloscope to terminal 2 of T1 in the Main Tuning Mixer and check the 100 kc positive-going pulse. See Figure 4-4. If no pulse is present, adjust L1 in the 100 kc oscillator until a pulse of maximum amplitude is obtained.

(10) Switch power supply off and on several times to check for reliable starting of the oscillator. Slight readjustment of L1 may be necessary for reliable operation.

(11) Attach the high impedance probe of the RF microvoltmeter to terminal 2 of transformer T1 in the Main Tuning Mixer. Keep the Main Tuning dial at 0.0 mc position. Adjust pulse level with C9 in the 100kc harmonic generator

MODEL 128A

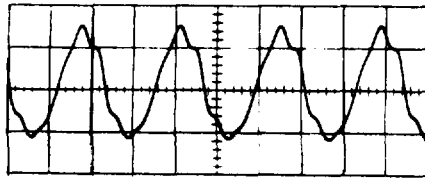

Vert: 1 V/cm
Hor: 20 nsec/cm
(581 Oscilloscope)

a. Main Tuning Oscillator output, capacitor plates fully meshed. Across 150 ohm dummy load connected to output of Main Tuning Follower output J8.

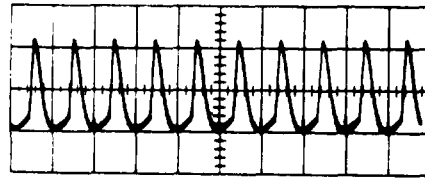

Vert: 1 V/cm
Hor: 10 usec/cm

b. Main Tuning Amplifier Detector output, collector of Q3. Locked waveform.

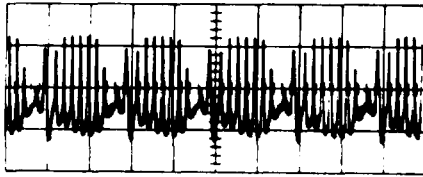

Vert: 1 V/cm
Hor: 50 usec/cm

c. Main Tuning Amplifier Detector output, collector of Q3. Unlocked waveform.

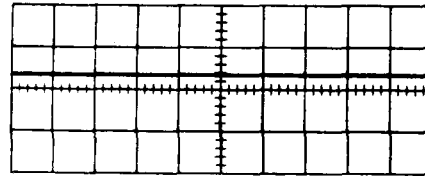

Vert: 2 V/cm
Hor: 50 usec/cm

d. 50 KC Low-Pass Filter output, junction of L1, C1, C2, R2. Locked waveform.

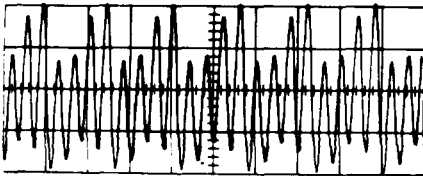

Vert: 2 V/cm
Hor: 50 usec/cm

e. 50 KC Low-Pass Filter output, junction of L1, C1, C2, R2. Unlocked waveform.

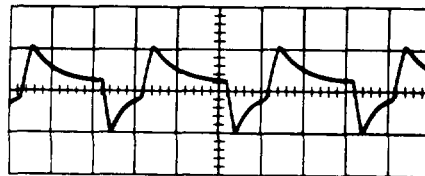

Vert: 2 V/cm
Hor: 10 usec/cm

f. Main Lock Indicator, junction of R5, R7, C4. Unlocked waveform.

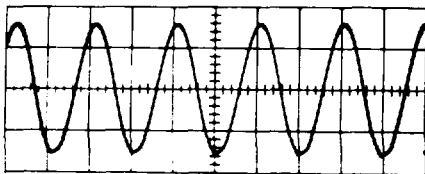

Vert: 1 V/cm
Hor: 5 usec/cm

g. 100 KC Oscillator and Harmonic Generator, oscillator output, junction of C5, C6, C7.

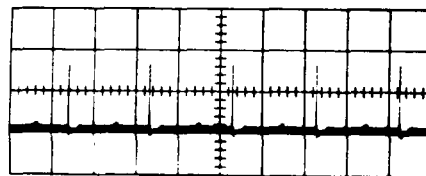

Vert: 5 V/cm
Hor: 5 usec/cm
(581 Oscilloscope)

h. 100 KC Pulse. Terminal 2 of transformer T1 in Main Tuning Mixer.

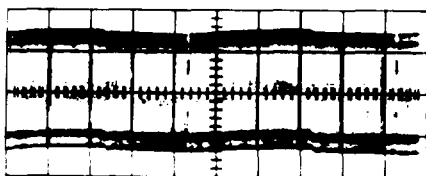

Vert: 5 V/cm
Hor: 2 usec/cm
(581 Oscilloscope)

i. Main Tuning Mixer, RF input. Terminal 4 of transformer T1.

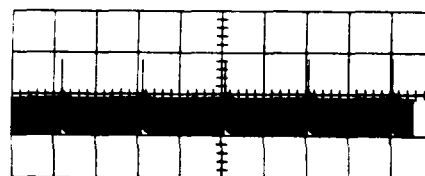

Vert: 5 V/cm
Hor: 5 usec/cm
(581 Oscilloscope)

j. Main Tuning Mixer output. Arm of R10.

Figure 4-4. Main Tuning Module, Waveforms

MODEL 128A

until the microvolt-meter reads 2.5 volts.

(12) Attach the microvoltmeter probe to terminal 4 of T1 in the Main Tuning Mixer and adjust the RF level with C3 until the microvoltmeter reads 0.55 volts.

(13) To adjust the balance of the Main Tuning Mixer, attach the probe of the Oscilloscope to TP6 on the Main Lock Indicator. Set sweep speed to 50 μ sec and the preamp to DC. The DC voltage range present, in locked condition, should be equal to or greater than 5 volts with the tuning capacitor plates in fully meshed position and equal to or greater than 2 volts with the tuning capacitor plates in the fully opened position, with no ac present over the whole range. This locking voltage range is controlled by C8 and R10 in the Main Tuning Mixer. The optimum position of these controls is arbitrary and can only be determined by a "trial and error" procedure.

(14) If ac shows up on the dc trace, reduce level slightly with C3 in Main Tuning Mixer. If the locking voltage range requirement cannot be met, readjust C3 in the Main Tuning Mixer and C9 in 100 kc oscillator. Check that no AC is present throughout range.

(15) Fasten side panels securely to the module. Connect the Frequency Counter with an adapter cable to J9. Tune the Counter converter to 36.1 mc. Set the Main Tuning dial to the locked frequency position at or closest to the 15.0 mc dial mark. Adjust C3 in the 100 kc oscillator (use small insulated tool) until the counter reads 36.1 mc \pm 2 cps.

b. Main Tuning Oscillator Tracking and Locking Adjustments

(1) Connect the Frequency Counter to J9 on the Main Tuning oscillator. Turn the Main Tuning mode switch to CONT.

(2) Check that the end frequencies are within +10 kc of 21.1 and 36.1 mc (0.0 and 15.0 on the dial). If not refer to paragraphs a. (7)-(9) above.

(3) Turn the Main Tuning Mode switch to lock. Check the frequency locking at each megacycle mark and note the tuning dial settings. If all frequencies read either high or low on the dial, shift the dial disc by loosening its set screw to achieve an even reading distribution, Tighten setscrew after dial disc is shifted. Recheck (2) and readjust the end frequencies according to paragraphs a. (7)-(9) if necessary.

(4) Starting at the high end check in 100 kc steps that frequency locking occurs at each step within the width of the dial mark. Adjust misalignments by slightly bending the outside capacitor plates. Access to the plates is through a hole in the top of the casting. (This step necessary only after major parts replacement or major overhaul.)

(5) Set the dial to exactly 1 mc and note counter reading. Switch the Main Tuning mode switch to CONT. Adjust R2 on the Main Tuning switch until the counter reading in CONT position is within \pm 1 kc of the counter reading in LOCK position.

MODEL 128A

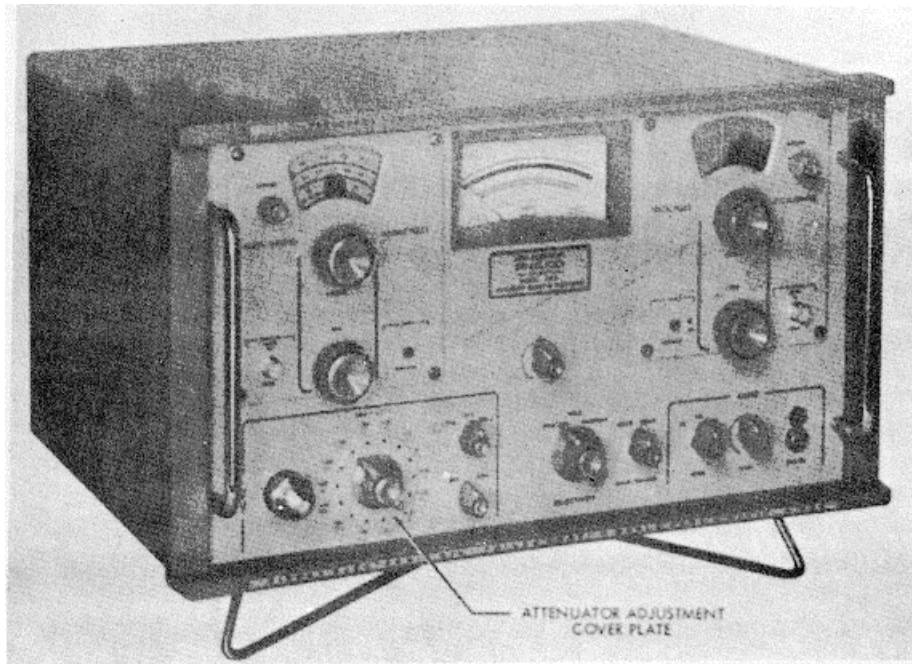

Figure 4-5. Front View, Module Location

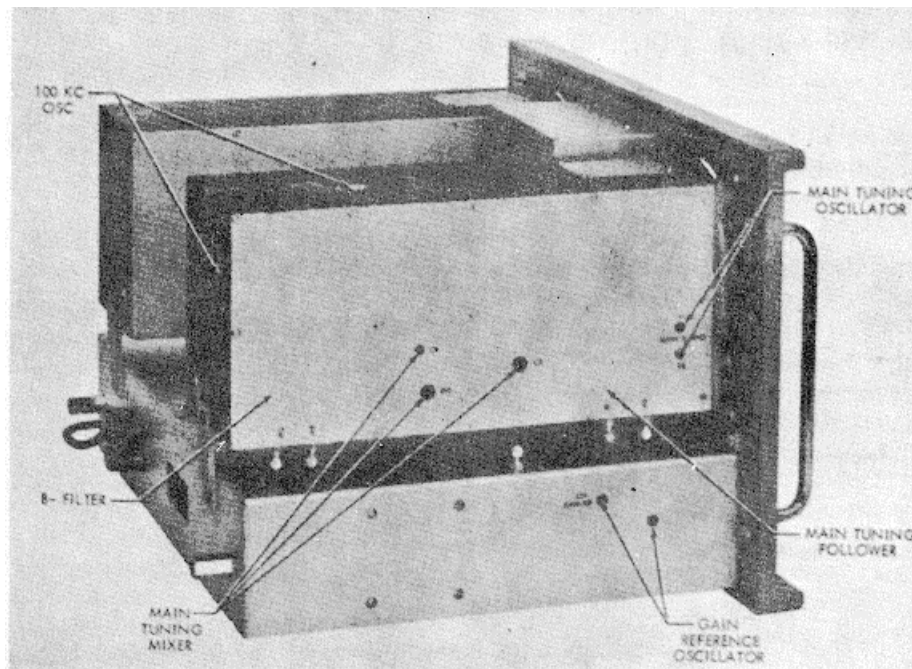

Figure 4-6. Left Side View, Module Location

MODEL 128A

12. Incremental Tuning Oscillator, Tracking and Locking

If the Incremental Tuning adjustments are badly out of line, follow the procedure in paragraph a. If normal service realignment is to be performed, start procedure with paragraph b. For waveforms and module location refer to Figures 4-7 through 4-10.

a. Adjustments, Incremental Tuning Oscillator, Locking.

(1) Attach probe of Oscilloscope to J20. The frequency should be about 19 mc and the voltage 6.2 volts p-p. See Figure 4-7a.

(2) Attach the Oscilloscope probe to terminal 2 of T1 in the Incremental Reference Mixer and check for the 2.5 volt p-p signal. See Figure 4-7b. If no signal is present, adjust L2 of the crystal oscillator until the signal appears and adjust for maximum amplitude.

(3) Switch the power supply off and on several times to check for reliable starting of the oscillator. Slight readjustment of L2 may be necessary to assure proper operation.

(4) Attach the probe of the oscilloscope to the junction of C12 and R4 in the Second Oscillator. Adjust the LOCK ADJ pot, R1, on the front panel until the voltage is -13.8 volts.

(5) Attach the probe of the Oscilloscope to terminal 2 of T1 in the Incremental Reference Mixer and connect the Frequency Counter to the output of the vertical amplifier of the oscilloscope. Adjust C3 in the Incremental Reference oscillator until the counter reads 18.585 mc I10 cps. Disconnect counter.

(6) Attach the Oscilloscope probe to the connection between R1 and the base of Q1 in the First LF amplifier. Keep the Incremental Tuning oscillator capacitor plates fully meshed and adjust R1 until the voltage corresponds to the voltage of Figure 4-7g.

(7) Set the Oscilloscope attenuator to 1V/cm and the preamplifier to DC. Short the oscilloscope probe to ground and adjust the vertical position control until the trace is on a reference grid line (zero volts DC reference). Attach the probe to TP7 on the incremental lock indicator. Adjust R3 in the second LF amplifier to mid-position and the tuning capacitor of the Incremental Tuning oscillator to full open position. Adjust L1 in the Second Oscillator until a DC voltage trace appears on the oscilloscope. Then adjust the DC voltage with L1 to the previously selected reference line (zero volts DC). If difficulties are encountered in obtaining a DC voltage, adjustment of R5 in the Phase Discriminator may be necessary.

(8) As soon as DC voltage is present the lock indicator light, below the tuning dial, should come on. The light should be off if AC voltage is present.

(9) Attach the oscilloscope probe to the output of the First LF amplifier (terminal 2 of T1 in Phase Discriminator) and fully mesh the Incremental Tuning Capacitor plates. Readjust R1 in the First LF amplifier until the waveform corresponds to the voltage of Figure 4-7i.

MODEL 128A

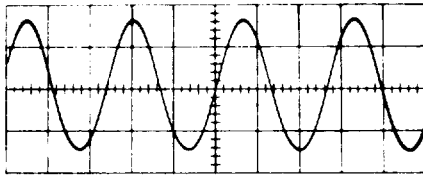

Vert: 2 V/cm
Hor: 20 nsec/cm

a. Second Oscillator output at J20.

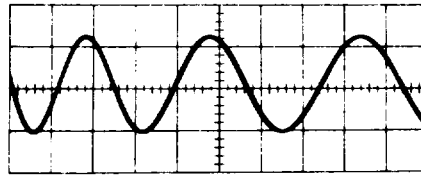

Vert: 2 V/cm
Hor: 20 nsec/cm

b. Incremental Reference Oscillator and Mixer, Crystal Oscillator output, terminal 2 of transformer T1. Second Oscillator disconnected.

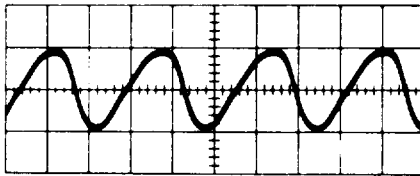

Vert: 2 V/cm
Hor: 20 nsec/cm

c. Incremental Reference Oscillator and Mixer, Second Oscillator input, terminal 4 of transformer T1.

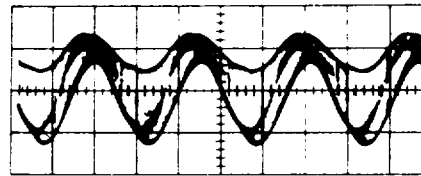

Vert: 0.1 V/cm
Hor: 2 usec/cm

d. Incremental Reference Oscillator and Mixer output, arm of R7. Incremental Tuning Oscillator capacitor plates meshed.

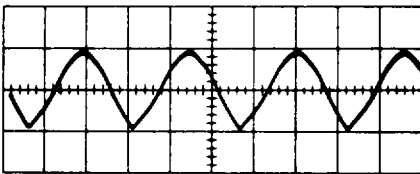

Vert: 2 V/cm
Hor: 2 usec/cm

e. Second L.F. Amplifier output. Terminal 1 of transformer T2 in Phase Discriminator. Incremental Tuning Oscillator capacitor plates meshed.

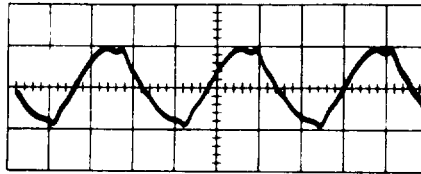

Vert: 2 V/cm
Hor: 1 usec/cm

f. Second L.F. Amplifier output. Terminal 1 of transformer T2 in Phase Discriminator. Incremental Tuning Oscillator capacitor plates open.

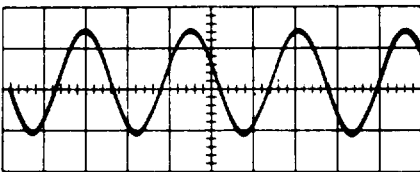

Vert: 0.2 V/cm
Hor: 2 usec/cm

g. First L.F. Amplifier Input, base of transistor Q1. Incremental Tuning Oscillator capacitor plates meshed.

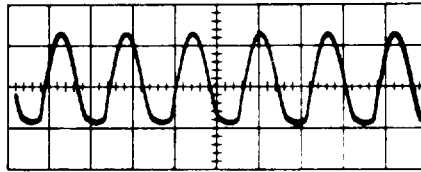

Vert: 0.5 V/cm
Hor: 2 usec/cm

h. First L.F. Amplifier Input, base of transistor Q1. Incremental Tuning Oscillator capacitor plates open.

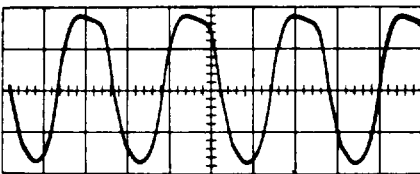

Vert: 2 V/cm
Hor: 2 usec/cm

i. First L.F. Amplifier output. Terminal 2 of transformer T1 in Phase Discriminator. Incremental Tuning Oscillator capacitor plates meshed.

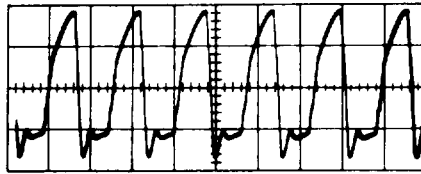

Vert: 2 V/cm
Hor: 2 usec/cm

j. First L.F. Amplifier output. Terminal 2 of transformer T1 in Phase Discriminator. Incremental Tuning Oscillator capacitor plates open.

Figure 4-7. Incremental Tuning Module, Waveforms I

MODEL 128A

(10) Attach the oscilloscope probe to the output of the Second LF amplifier (terminal 1 of T2 in Phase Discriminator). Readjust R3 in the Second LF amplifier until the waveform corresponds to the voltage of Figure 4-7e.

(11) Attach the oscilloscope probe to the output of the 125 kc Low-Pass Filter (TP7). Rotate the Incremental Tuning capacitor slowly through its range and observe the DC trace on the oscilloscope. If in some portions of the capacitor range a sine wave appears, readjust R5 in the Phase Discriminator. The oscilloscope trace must be DC throughout the tuning capacitor range.

(12) Switch the power supply off and on at every 10 kc increment over the tuning capacitor range. Allow at least 1/2 minute off-time of the power supply. Each time the power supply is switched on, the oscilloscope trace must return to dc. If it does not, slight readjustment of R1 in the First LF amplifier and/or R3 in the Second LF amplifier is necessary.

(13) Rotate the Incremental Tuning capacitor rapidly through its range. The locking system may momentarily go out of the locked condition and an ac voltage be present at the 125 kc Low-Pass Filter output (TP7). If the locking system does not immediately return to a stable dc condition, compensating readjustments of R 1 in the First LF amplifier, R3 in the Second LF amplifier and R5 in the Phase Discriminator are necessary.

(14) Connect the high impedance probe of the RF microvoltmeter to the inside connection of J20. Check that the output voltage over the frequency range of the oscillator is 0.8 volts \pm 0.1 volt. Fasten the side panels securely to the module.

b. Incremental Tuning Oscillator Tracking

(1) Rotate the Incremental Tuning capacitor over its range and check that the Lock Indicator light stays on. A slight readjustment (CCW) of L1 in the Second Oscillator may be necessary if the light stays out at any point.

(2) Set the Cursor index to midrange.

(3) Set the Incremental Tuning dial to 100 kc and check that the tuning capacitor is $11/32$ " from full mesh.

(4) Set Attenuator switch to 0 db.

(5) Using the Frequency Counter, set the Signal Generator to 1 mc \pm 10 cps. Set level to 0 db. Connect Signal Generator to INPUT of voltmeter.

(6) Set voltmeter Bandwidth switch to 250 ~.

(7) Set Main Tuning to 1 mc, locked condition.

MODEL 128A

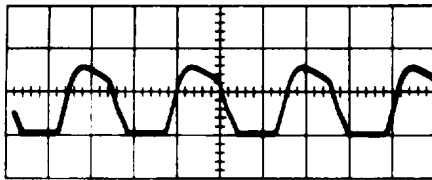

Vert: 20 V/cm
Hor: 2 usec/cm

a. Phase Discriminator, terminal 3 of transformer T1. Incremental Tuning Oscillator capacitor plates meshed.

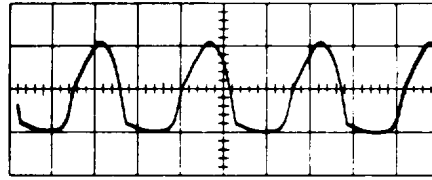

Vert: 20 V/cm
Hor: 2 usec/cm

b. Phase Discriminator, terminal 5 of transformer T1. Incremental Tuning Oscillator capacitor plates meshed.

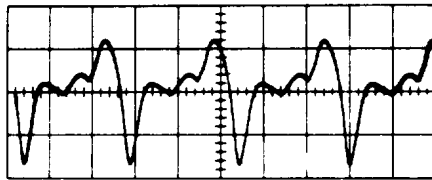

Vert: 5 V/cm
Hor: 2 usec/cm

c. Phase Discriminator, terminal 3 of transformer T2. Incremental Tuning Oscillator capacitor plates meshed.

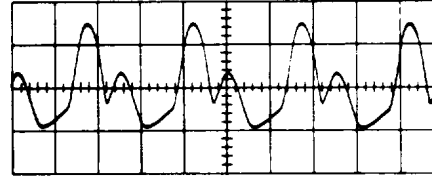

Vert: 5 V/cm
Hor: 2 usec/cm

d. Phase Discriminator, terminal 5 of transformer T2. Incremental Tuning Oscillator capacitor plates meshed.

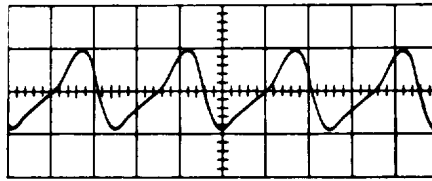

Vert: 2 V/cm
Hor: 2 usec/cm

e. Phase Discriminator output, junction of CR1 and R6. Incremental Tuning Oscillator capacitor plates meshed.

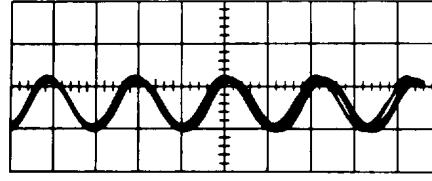

Vert: 5 V/cm
Hor: 10 usec/cm

f. 125 KC Low-Pass Filter output, junction of C10, C11, C12. Unlocked waveform.

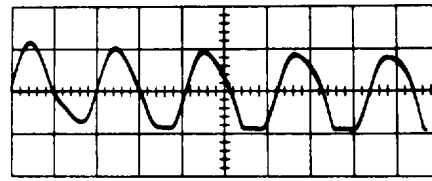

Vert: 2 V/cm
Hor: 10 usec/cm

g. Incremental Lock Indicator, junction of R5 and R7. Unlocked waveform.

Figure 4-8. Incremental Tuning Module, Waveforms II

MODEL 128A

- (8) Set Incremental Tuning dial to 0.0 kc.
- (9) Connect the AC VTVM to the Incremental Tracking Signal Input jack, J3. Connect the Frequency Counter to the AC VTVM output and adjust Range switch of VTVM until Frequency Counter operates properly.
- (10) Adjust C6 in the Incremental Tuning Oscillator until the Frequency Counter reads 300 kc +2 cps.
- (11) Adjust L2 in the Incremental Reference Oscillator for maximum reading of the panel meter.
- (12) Check that the end frequencies are within +20 cps of 300 kc (0 kc on dial) and 200 kc (100 kc on dial). Readjust C6 and L1 in the Incremental Tuning oscillator for correct readings if necessary. (Adjust L1 at 200 kc and C6 at 300 kc.)
- (13) Starting at the 300 kc end, check the dial settings in 10 kc steps. The 300 kc and 200 kc readings (0 kc and 100 kc dial settings) should be within ± 10 cps and all other readings within ± 200 cps of each corresponding dial setting. Each setting should be rocked into place with back and forward movements of the tuning knob to eliminate any back-lash irregularities. Record readings.
- (14) Note the tuning dial settings at all frequency points. If all frequencies read either high or low on the dial shift the capacitor, by loosening its set screws, to achieve an even reading distribution. Tighten set screws after dial scale is properly set. (This adjustment should only be necessary in case an adjustment was required in paragraph (3). Recheck and readjust as necessary the settings of paragraphs (12) and (13).
- (15) Adjust incorrect readings by slightly bending the tuning capacitor outside plates. Access to the plates is through the top hole of the Incremental Tuning Module casting. Check end points, paragraph (12) after every adjustment. Recheck dial settings, paragraph (13), after adjustments are complete.
- (16) Set the Incremental Tuning dial to read 300 kc ± 10 cps on the counter (0 kc dial setting). Disconnect the Frequency Counter from the AC VTVM and connect to the Signal Generator. Check that Signal Generator is still tuned to 1 mc ± 10 cps. (Main Tuning dial remains at 1.0 mc, locked condition.) Adjust L2 in the Incremental Reference oscillator for maximum deflection on the voltmeter panel meter.
- (17) Repeat the procedure of paragraph 12.a. (6). Make sure that no ac appears on trace over the whole range. Make sure DC voltage is at the zero volts reference line in the -10 kc dial position. Readjust L1 in the Second Oscillator if necessary.

MODEL 128A

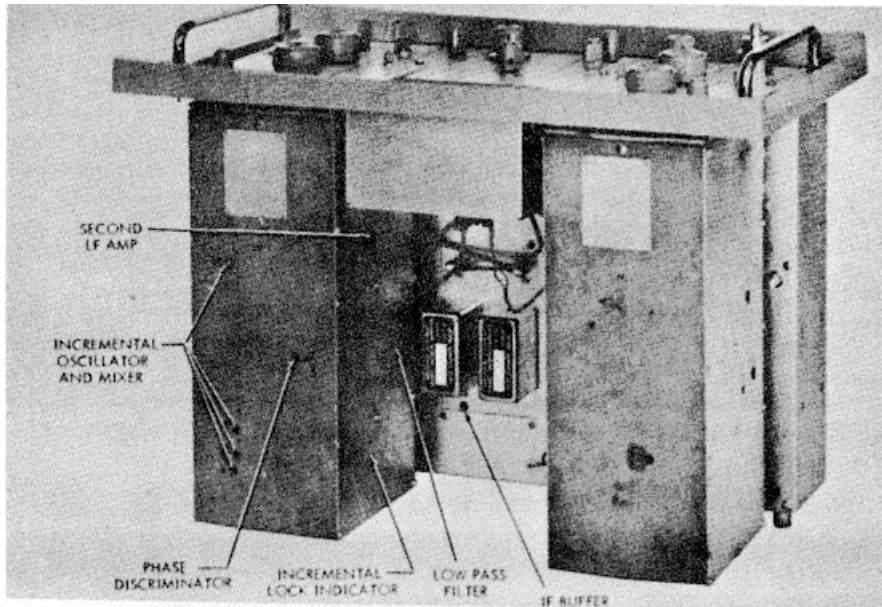

Figure 4-9. Top View, Module Location

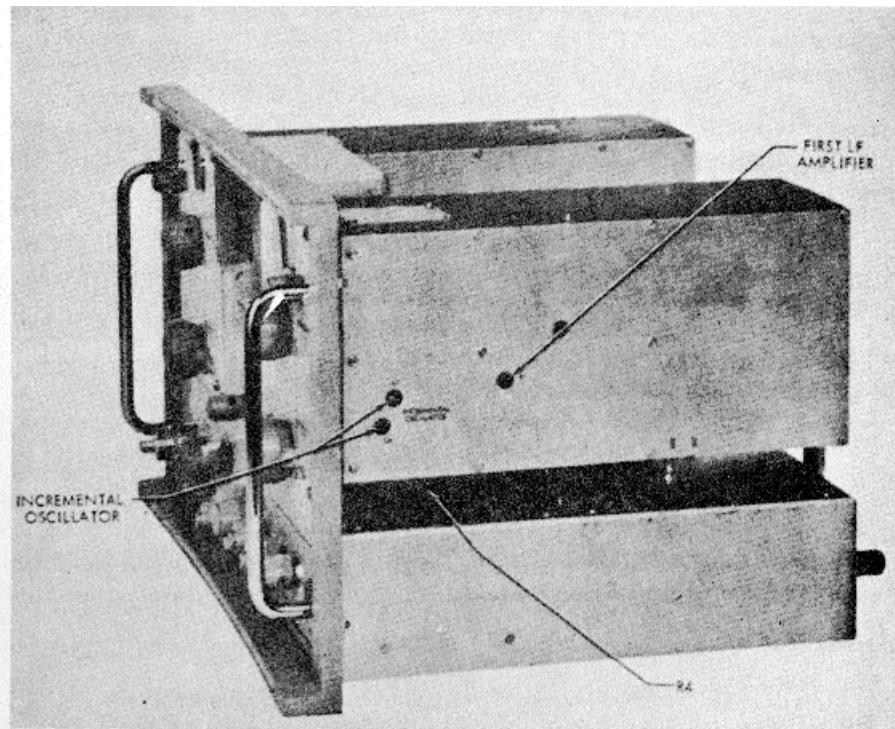

Figure 4-10. Right Side View, Module Location

MODEL 128A

13. Attenuator Calibration

a. Connect the Signal Generator to the VHF Attenuator and connect the AC VTVM to the Signal Generator output. Connect the VHF Attenuator to the voltmeter and terminate the voltmeter input with a 50 ohm coaxial termination load.

b. Switch the VHF Attenuator to the 100 db position. Set the Signal Generator to 1 mc and adjust the output to read 0.866 volts on the AC VTVM. Set the voltmeter Attenuator to -90 db, 75 ohm/BRG and the bandwidth switch to 250 ~.

c. Tune the voltmeter to 1 mc and adjust the CAL control to midrange. Set R19 in the Output Amplifier for a voltmeter panel meter reading of 0 db.

d. Switch the voltmeter Attenuator to -80 db, the VHF Attenuator to the 90 db position and check that the panel meter again reads 0 db. If it does not, readjust R4 in the Output Amplifier for a 0 db reading.

e. Switch the impedance switch to 135 ohm/BRG. Check that the meter reading drops 2.56 db from the 0 db mark. Adjust C29 in the attenuator if necessary for an exact -2.56 db reading.

f. Switch the impedance switch to 600 ohm/BRG. Check that the meter reading drops 9.04 from the 0 db mark. Adjust C31 in the Attenuator if necessary for an exact -9.04 db reading.

g. Switch the Attenuator to 0 db and the VHF Attenuator to the 10 db position. Set the impedance switch to 135 ohm/BRG. Adjust the 0 db Attenuator trimmer for an exact -2.56 db meter reading. (Access to the Attenuator trimmer capacitors is obtained by removing the cover plate under the Attenuator knob. The plate is held by two screws which are accessible when the Attenuator knob is removed. Each trimmer is located under the corresponding panel db marking.)

h. Switch the impedance switch to 75 ohm/BRG. Adjust C27 in the Attenuator for an exact 0 db reading if necessary.

i. Switch VHF Attenuator to the 20 db position. Meter should read -10 db. Switch VHF Attenuator to the 30 db position. Meter should read -20 db. Record readings. If readings vary more than ± 0.2 db at -10 db and more than ± 1.0 db at -20 db the CAL Range adjustment may be set near the end of its range. Recheck paragraph c. above. Both CAL Range adjustment and CAL control should be set close to the mid range position for best meter linearity.

j. Switch the voltmeter Attenuator to CAL and tune for a maximum meter indication of the internal 1 mc calibration signal, then adjust L1 in the Gain Reference oscillator for maximum meter indication.

MODEL 128A

k. Adjust C23 in the Gain Reference oscillator for an exact 0 db reading.

l. Switch the VHF Attenuator to the 80 db position and the voltmeter Attenuator to -70 db. Adjust the -70 db Attenuator trimmer for a 0 db panel meter reading.

m. Proceed in like manner for the rest of the Attenuator steps, simultaneously decreasing the voltmeter Attenuator and the VHF Attenuator positions by 10 db and adjust each Attenuator trimmer for a 0 db meter reading. The +20 db and +30 db adjustments can be made at the -10 and -20 db meter marks. Check the frequency tuning of the voltmeter after each change in the attenuator setting.

14. 110 KC Bandpass First IF

a. Connect the Signal Generator to the voltmeter input, tune to 1 mc and monitor the input with the AC VTVM. Set the voltmeter CAL control for an exact 0 db meter reading.

b. Shift the frequency of the Signal Generator over the range of the Incremental Tuning oscillator from -10 kc to 100 kc by tuning the Incremental Tuning oscillator and the Signal Generator. Maintain the input level constant.

c. Record the meter deviation at every 10 kc step. Limit: ± 0.1 db.

d. If the limit is exceeded, recheck that L5, L6 and L7 in the First IF are correctly peaked (paragraph 7) and tune L7 to compensate for end point discrepancies. Tighten lock nuts on L5, L6, and L7.

15. General Checks

a. Disconnect all equipment from voltmeter input. Switch the voltmeter Attenuator to 0 db, 600 ohm/TERM and the Bandwidth switch to 250 ~. Set the Main Tuning dial to 0.0 mc and the Incremental Tuning dial to 10 kc. Residual meter reading must be below -15 db. Replace Q1 (2N706B) in the Preamplifier if the limit is exceeded.

b. Connect the Signal Generator, terminated with 50 ohms, to the voltmeter input. Set the voltmeter to 75 ohm/BRG. Check the frequency response at 100 kc, 1 mc, 10 mc and 15 mc. Frequency response must be flat within ± 0.2 db from 100 kc to 10 mc and ± 0.5 db to 15 mc. Adjust C8 in the Preamplifier for the 15 mc response. Replace Q1 in the Preamplifier if the limits are exceeded and recheck paragraph a.

MODEL 128A

**SECTION V.
REPLACEABLE PARTS LIST**

PARTS REPLACEMENT

Standard components have been used in this instrument whenever possible. Identify parts by their Sierra stock numbers. Order replacement parts through normal supply channels.

When ordering parts always include:

1. Sierra Stock Number.
2. Circuit Reference and Commercial Description.
3. Name, Model and Serial Number of the Instrument.

MODEL 128A

REPLACEABLE PARTS LIST

A. INTRODUCTION

Each printed circuit board module in the instrument is given a separate number and a name and each has a separate series of component numbers. Two module numbers may apply to the same set of components. These cases are listed below:

- Audio, SA0181281 includes module B02051100.
- Function (Bandwidth), B02050600 includes module B01864800.
- Output Amplifier, SA0571281 includes module B02051000.

Modulator (First and Second), SA2741281 are two modules bearing the same number and having identical components.

Chassis, SA0171281 lists the front panel and chassis components not included in other modules. The number does not appear on the schematic diagram.

In some cases, on the schematic diagram, several smaller printed circuit board modules are shown within a larger dashed line area indicating a larger module. The smaller module components are listed separately in the parts list under the module name. Components on a casting but not on the printed circuit board modules are listed separately according to casting name. Components on the front panel and main chassis are listed separately.

The Replaceable Parts List is grouped according to the names of the different modules. An alphabetical index follows:

	page
Amplifier Detector, B02002800	5-25
Attenuator, D01987000	5-11
Audio SA0181281 (B02051100).....	5-5
B- Filter B02003200	5-26
Chassis, SA0171281	5-4
First L.F. Amplifier, B02044400.....	5-17
First Mixer, B02050200	5-10
Function (Bandwidth), B02050600 (B01864800)	5-7
Gain Reference, B01999500.....	5-13
I.F. Buffers, B02050700	5-7
Incremental Lock Indicator, B02002300.....	5-21
Incremental Reference Oscillator & Mixer, B02045000	5-18

MODEL 128A

	page
Incremental Tuning Casting, B02063500.....	5-16
Incremental Tuning Oscillator, B02001600	5-16
Input Low-Pass Filter 16 mc, First I.F. and Mixer Module Casting, B02050100.....	5-9
Low-Pass Filter 125 kc, B02002200.....	5-20
Low-Pass Filter 50 kc, Input Stage, B02002900	5-24
Low-Pass Filter 50 kc, Output Stage, B02003000	5-24
Main Lock Indicator, B02003100.....	5-25
Main Tuning (Mode Switch) B02001500	5-16
Main Tuning Casting, B02063600.....	5-21
Main Tuning Follower, B02044800.....	5-22
Main Tuning Mixer, B02002700	5-24
Main Tuning Oscillator, B01999600	5-22
Modulator (First and Second), B02050300	5-10
Narrow Band Follower, B02050800	5-8
100 KC Oscillator & Harmonic Generator, B02002600.....	5-23
Output Amplifier, SA0571281 (B02051000).....	5-14
Phase Discriminator, B02002100.....	5-20
Power Supply, B02051200.....	5-4
Preamplifier, B02163000.....	5-12
Second I.F., B02050500.....	5-11
Second L.F. Amplifier, B02002000.....	5-19
Second Mixer, B02050400	5-11
Second Oscillator, B02044600.....	5-17
Wide Band Follower, B02050900.....	5-9

MODEL 128A

REPLACEABLE PARTS LIST

Schem. Ref. No.	Description	Sierra Stock No.	Mfr.	Dwg. or Mfr. No.	Tot. Quan.
	CHASSIS - SA0171281				
C1	CAPACITOR, Feed Thru, 1000 pf 500V	902640102	Erie	1201-052	13
C2	Same as C1				
C3	Same as C1				
C4	Not used				
C5	Same as C1				
F1	FUSE, .25A, 3AG Slo-Blo	913200033	Littelfuse	313.300	1
F2	FUSE, 3/100A, 250V, 3AG	913200032	Littelfuse	312.250	1
J1B	CONNECTOR, Adapter to BNC for 874-PRLT	914600089	General Radio	874-QBJL	1
J6	BINDING POST, Red	915200008			1
J7	BINDING POST, Black	915200009			1
J29	CONNECTOR, Solder Receptacle	914600099	AMP	3298852	1
P1	LINE CORD, 18/3 Cond. SV 8 Ft. w/plug	916400017	Belden	17238	1
P29	CABLE ASSY		Sierra	B01920501	1
TP3	INSULATOR, Feed Thru Teflon	915100029	Lerco	6090	3
XF1	FUSE HOLDER	913400014	Littelfuse	342004	2
XF2	Same as XF 1				
	POWER SUPPLY - B02051200 (SA2931281)				
C1	CAPACITOR, Type PFP W/Insul. Cover 5009µf 50V	902200507	Mallory	TS-19021	3
C2	CAPACITOR, Verti-Lytic 25 µf, 50V	902220256	Sprague	VL-1310 6234-J	1
C3	Same as C1				
C4	Same as C1				
C5	CAPACITOR, .05/f, 100V	901100503	El-Menco	1DP-2-503	1
C6	CAPACITOR, Disc Ceramic 2X.02	901410203	Sprague		
C7	Part of C6				
C8	CAPACITOR, Vert. Mtg. Plastic Encased 50 µf 25V NP	903300506	Nashville Elec.	16-437BP-50- 25585 NP	4
CR1	DIODE, Zener IN707A 7. 1V	910500032	International Rect.	1N707A	1
CR2	DIODE, DI 56	910800008		DI 56	5
CR3	Same as CR2				
CR4	Same as CR2				
CR5	Same as CR2				
CR6	Same as CR2				
E1	HEAT SINK	921300001	Birtcher	3AL-672	1
K1	RELAY, 105-126 VAC SPDT P.C. Mounting	912600027	Phillips	4BAC30C	1
Q1	TRANSISTOR, NPN 2N706A	910300022	Motorola	2N706A	15
Q2	TRANSISTOR, PNP 2N508	910300015	Motorola	2N508	2
Q3	Same as Q2				
Q4	TRANSISTOR, PNP 2N375	910300021	Motorola	2N375	1

MODEL 128A

REPLACEABLE PARTS LIST

Schem. Ref. No.	Description	Sierra Stock No.	Mfr.	Dwg. or Mfr. No.	Tot. Quan.
R1	RESISTOR, Fixed Composition 3300±5% 1/4W	906900332	Speer		11
R2	RESISTOR, Variable 10 Turn Type R 500Ω	907900102	AB		6
R3	RESISTOR, Fixed Composition 5600Ω±5% 1/4W	906900562	Speer		11
R4	RESISTOR, Fixed Composition 56K ±5%, 1/4W	906900563	Speer		6
R5	RESISTOR, Fixed Composition 220K ±5%, 1/4W	906900224	Speer		3
R6	RESISTOR, Fixed Composition 4700Ω+5%, 1/4W	906900472	Speer		10
R7	Same as R1				
R8	RESISTOR, Fixed Composition 6800Ω+5%, 1/4W	906900682	Speer		8
R9	RESISTOR, Fixed Composition 100K±5%, 1/4W	906900104	Speer		3
R10	RESISTOR, Fixed Composition 6800Ω±10%, 2W	906000682	AB	HB	1
R11	RESISTOR, Fixed Composition 10Ω±10%, 2W	906000100	AB	HB	
T1	TRANSFORMER, 115 VAC - 25 VAC Nom.	910000059	Foster	A01896500	1
XQ1	SOCKET TRANSISTOR, 3 Pin	914200036	Groyhill	22-16-3	45
XQ2	Same as XQ 1				
XQ3	Same as XQ 1				
	AUDIO - B02051100				
C1	CAPACITOR, Disc Ceramic 0.1 μf, 50V	901410104	Sprague	33C41	40
C2	CAPACITOR, Disc Ceramic .01 μf, 150V	901440103	Centralab	DDM-103	64
C3	CAPACITOR, Vert. Mtg. Plastic Encased 10 μf, 25V Normal Position	903300106	Nashville Elect.	12-375BP10-25S85NP	9
C4	Same as C1				
C5	CAPACITOR, Dura Mica, 47 pf, ±5%, 500V	901900470	El-Menco	DM15-470J	3
C6	CAPACITOR, Dura Mica, 3000 pf, ±5%, 500V	901900302	El-Menco	DMI9-302J	1
C7	CAPACITOR, Vert. Mtg. Plastic Encased 50 μf,25V Normal Position	903300506	Nashville Elect.	16437BP50-25S85NP	*
C8	Some as C1				
C9	Some as C				
C10	Some as C7				
C11	Some as C3				
C12	Some as C7				
C13	Some as C3				
C14	Some as C3				
C15	CAPACITOR, Vert. Mtg. Plastic Enclosed 22 μf,25V Normal Position	903300226	Nashville Elect.	16375BP22-25S85NP	17
C16	Same as C				
C17	Some as C1				
C18	CAPACITOR, Dura Mica 390 pf, ±5%, 500V	901900391	El-Menco	DM15-391J	4
C19	Same as C1				
C20	Same as C1				
C21	Same as C1				
C22	Same as C1				
C23	CAPACITOR, Dura Mica 68 pf, ±5%, 500V	901910680	El-Menco	DM15-680J	2
C24	Same as C18				
C25	Same as C1				
C26	Same as C1				
C27	Same as C23				
C28	Some as C2				
C29	Same as C2				
C30	Some as C1				

*Previously Accounted For

MODEL 128A

REPLACEABLE PARTS LIST

Schem. Ref. No.	Description	Sierra Stock No.	Mfr.	Dwg. or Mfr. No.	Tot. Quan.
J4	JACK, Phone	914400014	Switchcraft	13E-JAX	1
P25	CABLE ASSEMBLY		Sierra	B0208440;	2
L1	INDUCTOR, Variable	A01897400	Sierra	A01897400	8
L2	INDUCTOR, Fixed 3.3 mn	909000116	J.W. Miller	70F333A1	14
L3	Same as L1				
L4	Same as L1				
L5	INDUCTOR, Fixed 24 μh Molded	909000121	Delevan	1537-46	8
L6	Same as L5				
R1	RESISTOR, Fixed Composition, 56K, ±5%, 1/4W	906900563	Speer		*
R2	RESISTOR, Fixed Composition, 33K, ±5%, 1/4W	906900333	Speer		13
R3	RESISTOR, Fixed Composition, 100K, ±5%, 1/4W	906900104	Speer		*
R4	RESISTOR, Fixed Composition, 47Ω, ±5%, 1/4W	906900470	Speer		3
R5	RESISTOR, Fixed Composition, 6800Ω, ±5%, 1/4W	906900682	Speer		*
R6	RESISTOR, Fixed Composition, 1000Ω, ±5%, 1/4W	906900102	Speer		17
R7	RESISTOR, Fixed Composition, 22K, ±5%, 1/4W	906900223	Speer		8
R8	RESISTOR, Fixed Composition, 120K, ±5%, 1/4W	906900124	Speer		4
R9	RESISTOR, Fixed Composition, 2200Ω, ±5%, 1/4W	906900222	Speer		13
R10	RESISTOR, Fixed Composition, 4700Ω, ±5%, 1/4W	906900472	Speer		*
R11	RESISTOR, Fixed Composition, 5600Ω, ±5%, 1/4W	906900562	Speer		*
R 12	Same as R7				
R13	RESIST(R, Fixed Composition, 560Ω, ±5%, 1/4W	906900561	Speer		9
R14	RESISTOR, Fixed Composition, 10K, ±5%, 1/4W	906900103	Speer		14
R15	Same as R13				
R16	RESISTOR, Fixed Composition, 39K, ±5%, 1/4W	906900393	Speer		10
R17	Same as R14				
R18	Same as R6				
R19	Same as R14				
R20	RESISTOR, Fixed Composition, 8200Ω, ±5%, 1/4W	906900822	Speer		5
R21	Same as R10				
R22	RESISTOR, Fixed Composition, 270052, 5%, 1/4W	906900272	Speer		13
R23	RESISTOR, Fixed Composition, 270Ω, :5%, 1/4W	906900271	Speer		3
R24	RESISTOR, Fixed Composition, 1500Ω, :5%, 1/4W	906900152	Speer		6
R25	RESISTOR, Fixed Composition, 12K, ±5%, 1/4W	906900123	Speer		10
R26	RESISTOR, Fixed Composition, 100Ω, +5%, 1/4W	906900101	Speer		7
R27	Same as R9				
R28	Same as R9				
R29	Same as R 14				
R30	Same as R20				
R31	Same as R10				
R32	Some as R22				
R33	Same as R23				
R34	Same as R24				
R35	Same as R25				
R36	Same as R26				
R37	Same as R9				
R38	Same as R9				
R39	POTENTIOMETER, 100K, 2W	907900037	Sierra	SS-393337	1
56	SWITCH, Rotary, 2 Pole, 3 Pos.	911200058	Oak	SS-14206-1	1
Q1	TRANSISTOR, PNP 2N2360	910300017	Philco	2N2360	10
Q2	TRANSISTOR, PNP 2N1745	910300020	Philco	2N1745	9

*Previously Accounted For

MODEL 128A

REPLACEABLE PARTS LIST

Schem. Ref. No.	Description	Sierra Stock No.	Mfr.	Dwg. or Mfr. No.	Tot. Quan.
Q3 Q4 Q5 Q6 Q7 Q8 Q9	TRANSISTOR, PNP 2N1728 Same as Q3 TRANSISTOR, PNP 2N414 910300004 Raytheon 2N414 4 Same as Q3 Same as Q2 Same as Q3 Same as Q2	910300008	Philco	2N1728	11
XQ1 XQ2 XQ3 XQ4 XQ5 XQ6 XQ7 XQ8 XQ9	SOCKET, Transistor, 4 Pin SOCKET, Transistor, 3 Pin Same as XQ2 Same as XQ2 Same as XQ2 Same as XQ2 Same as XQ2 Same as XQ2 Same as XQ2	914200037 914200036	Grayhill Grayhill	22-16-4 22-16-3	13 *
XY1 XY2	SOCKET CRYSTAL Same as XY1	914200007	Millen	33302	4
Y1 Y2	CRYSTAL, 2213.500 Kc CRYSTAL, 2216.500 Kc	912200028 912200029	Wright Wright	A01896900 A01896800	1 1
FUNCTION (BANDWIDTH) - B02050600					
C1 C2 C3	CAPACITOR, Feed Thru, 1000 pf, 500V Same as C1 Same as C1	902640102	Erie	1201-052	*
FL1 FL2	FILTER, Crystal, 250 cps FILTER, Crystal, 3100 cps	910100004 910100017	Blackhawk Blackhawk	SS-14486-1 A02088500	1 1
J23 J24 J25	CONNECTOR, Screw Type, Bulkhead Same as J23 Same as J23	914600099	Amp	329852	15
L1	INDUCTOR, Fixed, 3.3 mh	909000116	J.W. Miller	70F333A	*
R1	RESISTOR, Fixed Composition, 560Q, ±5%, 1/4W	906900561	Speer		*
51	SWITCH, Rotary, Slide, P.C. Mounting (4 Decks) SHAFT for above decks	911200100 911200101	Oak Oak	B01894500 B01921200	1 1
I.F. BUFFERS - B02050700					
C1 C2 C3 C4 C5 C6	CAPACITOR, Dura Mica, 220pf, *5%, 500V CAPACITOR, .01 Disc Ceramic, 150V Same as C Same as C2 Same as C Same as C2	901900221 901440103	El-Menco Centralab	DM15-221J DDM-103	4 *
*Previously Accounted For					

MODEL 128A

REPLACEABLE PARTS LIST

Schem. Ref. No.	Description	Sierra Stock No.	Mfr.	Dwg. or Mfr. No.	Tot. Quan.
C7	Same as C2				
C8	Same as C2				
C9	Same as C2				
C10	Same as C2				
C11	Same as C2				
L1	INDUCTOR, 24 μ h, Molded	909000121	Delevan	1537-46	*
Q1	TRANSISTOR, 2N1728, PNP	910300008	Philco	2N1728	*
Q2	Same as Q1				
R1	RESISTOR, Fixed Composition, 2.2K \pm 5%, 1/4W	906900222	Speer		2
R2	RESISTOR, Fixed Composition, 27K \pm 15%, 1/4W	906900273	Speer		2
R3	RESISTOR, Fixed Composition, 180 Ω \pm 5%, 1/4W	906900181	Speer		1
R4	RESISTOR, Fixed Composition, 100 Ω \pm 5%, 1/4W	906900101	Speer		*
R5	RESISTOR, Fixed Composition, 1000 Ω \pm 5%, 1/4W	906900102	Speer		*
R6	RESISTOR, Fixed Composition 270 Ω \pm 5%, 1/4W	90690027			1
R7	RESISTOR, Fixed Composition 2700 Ω \pm 5%, 1/4W	906900272			2
R8	Same as R1				
R9	Same as R2				
R10	Not Used				
R11	RESISTOR, Variable, 25 Turn, 150v, Type RP	907900171	AB	RP 151M	1
R12	Same as RS				
R13	RESISTOR, Fixed Composition, 220 Ω \pm 5%, 1/4W	906900221			2
R14	Same as R7				
R15	Same as R13				
R16	RESISTOR, Fixed Composition, 120 Ω \pm 5%, 1/4W	906900121	Speer		1
XQ1	TRANSISTOR Socket, 3 Pin	914200036	Grayhill	22-16-3	*
XQ2	Same a XQ1				
C1	NARROW BAND FOLLOWER - 802050800				
C2	CAPACITOR, .01 Disc Ceramic, 150V	901440103	Centerlab	DDM-103	*
C3	Same as C1				
C4	Same as C1				
Q1	TRANSISTOR, 2N2360, PNP	910300017	Philco	2N2360	*
R1	RESISTOR, Fixed Composition, 3900 Ω \pm 5%, 1/4W	906900392	Speer		5
R2	RESISTOR, Fixed Composition, 100 Ω \pm 5%, 1/4W	906900101	Speer		*
R3	RESISTOR, Fixed Composition, 220 Ω \pm 5%, 1/4W	906900222	Speer		*
R4	RESISTOR, Fixed Composition, 39K \pm 5%, 1/4W	906900393	Speer		*
R5	RESISTOR, Fixed Composition, 3300 Ω \pm 5%, 1/4W	906900332	Speer		*
R6	RESISTOR, Fixed Composition, 33K \pm 5%, 1/4W	906900333	Speer		*
XQ1	TRANSISTOR, Socket, 4 Pin	914200037	Grayhill	22-16-4	*

*Previously Accounted For

MODEL 128A

Section V

REPLACEABLE PARTS LIST

Schem. Ref. No.	Description	Sierra Stock No.	Mfr.	Dwg. or Mfr. No.	Tot. Quan.
	WIDEBAND FOLLOWER - B02050900				
C1	CAPACITOR, .01 Disc Ceramic, 150V	901440103	Centralab	DDM-103	*
C2	Same as C1				
C3	Same as C1				
C4	Some as C1				
C5	Some as C1				
Q1	TRANSISTOR, 2N2360, PNP	910300017	Philco	2N2360	*
Q2	Same as Q1				
R1	RESISTOR, Fixed Composition, 1500 Ω, ±5%, 1/4W	906900152	Speer		*
R2	RESISTOR, Fixed Composition, 2700Ω, ±5%, 1/4W	906900272	Speer		*
R3	RESISTOR, Fixed Composition, 2200Ω, ±5%, 1/4W	906900222	Speer		*
R4	RESISTOR, Fixed Composition, 33K, ±5%, 1/4W	906900333	Speer		*
R5	RESISTOR, Fixed Composition, 39K, ±5%, 1/4W	906900393	Speer		*
R6	RESISTOR, Fixed Composition, 3300Ω, ±5%, 1/4W	906900332	Speer		*
R7	Same as R4				
R8	Same as R5				
R9	Same as R6				
XQ1	TRANSISTOR Socket, 4 Pin	914200037	Grayhill	22-16-4	*
XQ2	Some as XQ1				
	INPUT LOW-PASS FILTER 16 mc, FIRST I.F. AND MIXER MODULE CASTING - B02050100				
C1	CAPACITOR, Silver Mica, 5 pf, ± 20%, 500V	902040050	El-Menco	CM15C050M	2
C2	CAPACITOR, Silver Mica, 50 pf, ±2%, 500V	902070500	El-Menco	CM15E500G	1
C3	CAPACITOR, Silver Mica, 82 pf, ±2%, 500V	902050820	El-Menco	CM15E820G	1
C4	CAPACITOR, Silver Mica, 12 pf, ±5%, 500V	902010120	El-Menco	CM15E120J	1
C5	CAPACITOR, Silver Mica, 33 pf, ±2%, 500V	902070330	El-Menco	CM15E330G	3
C6	Same as C5				
C7	CAPACITOR, Silver Mica, 100 pf, ±5%, 500V	902010101	El-Menco	CM15E101J	2
C8	Same as C7				
C9	CAPACITOR, Silver Mica, 10 pf, ±5%, 500V	902010100	El-Menco	CM15E100J	1
C10	CAPACITOR, Silver Mica, 39 pf, ± 5%, 500V	902010390	El-Menco	CM15E390J	1
C11	Some As C5				
C12	CAPACITOR, Disc Ceramic, 0.1 μf, 50V	901410104	Sprague	33C41	*
C13	CAPACITOR, Tubular Ceramic, 27 pf, NPO	901400270	Centralab	TCZ27	3
C14	CAPACITOR, Ceramic, NPO-C1, 0.68 pf	901410068	Aero Vox	CC21CKR68C	1
C15	Same as C13				
C16	CAPACITOR, Ceramic, NPO-C1, 0.50 pf	901400005	Aero Vox	CC21CKR50C	1
C17	Some as C13				
C18	CAPACITOR, Silver Mica, 220 pf, ±2%, 500V	902070221	El-Menco	CM15E221G	1
C19	CAPACITOR, Feed Thru, 1000 pf, 500V	902640102	Erie	1200-052	*
C20	Same as C19				
J17	CONNECTOR, Screw Type, Bulkhead	914600099	Amp	329852	*
J21	Same as J17				
P23	CABLE ASSEMBLY		Sierra	B02084400	1
J32	Same as J17				

*Previously Accounted For

MODEL 128A

Section V

REPLACEABLE PARTS LIST

Schem. Ref. No.	Description	Sierra Stock No.	Mfr.	Dwg. or Mfr. No.	Tot. Quan.
L1	INDUCTOR, Variable	909400050	Delevan	220-10/R	2
L2	INDUCTOR, Variable	909400048	Delevan	220-06/R	1
L3	Same as L1				
L4	INDUCTOR, Variable	909400049	Delevan	220-OB/R	1
L5	INDUCTOR, Variable	A01985200	Sierra	A01985200	3
L6	Same as L5				
L7	Same as L5				
MODULATOR (FIRST AND SECOND) - B02050300					
C1	CAPACITOR, Dura Mica, 5 pf, 500V	901900050	El-Menco	DM15-050K	6
C2	CAPACITOR, Glass Piston, P.C. Mtg. .8-.8 .5 pf	903000885	Erie	563-013	8
C3	Some as C1				
C4	Same as C2				
CR1	DIODE	910500033	Hughes	HD1871E	4
CR2	Same as CR1				
R1	RESISTOR, Metal Film, 150 Ω, ±1%, 1/8W	907300002	Electro	MF 1/8	4
R2	Same as R1				
R3	RESISTOR, Variable, 500Ω, 25 Turn, Type R	907900102	AB		*
R4	RESISTOR, Metal Film, 274Ω, ±1%, 1/8W	907300003	Electra	MF 1/8	4
R5	Same as R4				
R6	RESISTOR, Metal Film, 56.2K, ±1%, 1/8W	907300001	Electra	MF 1/8	4
R7	Same as R6				
T1	TRANSFORMER, 1:1 Center Tapped Sec.	C01921400	Sierra	C01921400	4
FIRST MIXER - B02050200					
C1	CAPACITOR, Vert. Mounting, Plastic Encased, 1.0 μf, 25V, Normal Position	903300105	Nashville Elect.	8-250BP1-25S85 NP	10
C2	CAPACITOR, Disc Ceromic,.01, 150V	901440103	Centralab	DDM-103	*
C3	Same as C1				
C4	Same as C1				
Q1	TRANSISTOR, 2N2997, PNP	910300019		2N2997	1
R1	RESISTOR, Fixed Composition, 150Ω, ±5%, 1/4W	906900151	Speer		5
R2	RESISTOR, Fixed Composition, 47K, ±5%, 1/4W	906900473	Speer		4
R3	RESISTOR, Fixed Composition, 33K, ±5%, 1/4W	906900333	Speer		*
R4	RESISTOR, Fixed Composition, 10Ω, ±5%, 1/4W	906900100	Speer		2
R5	RESISTOR, Fixed Composition, 4700Ω, ±5%, 1/4W	906900472	Speer		*
R6	RESISTOR, Fixed Composition, 1000Ω, ±5%, 1/4W	906900102	Speer		*
R7	RESISTOR, Fixed Composition, 220Ω, ±5%, 1/4W	906900221	Speer		3
XQ1	TRANSISTOR, Socket 4 Pin	914200037	Groyhill	22-16-4	*

*Previously Accounted For

MODEL 128A

Section V

REPLACEABLE PARTS LIST

Schem. Ref. No.	Description	Sierra Stock No.	Mfr.	Dwg. or Mfr. No.	Tot. Quan.
	SECOND MIXER - B02050400				
C1	CAPACITOR, Vert. Mounting, Plastic Encased 1.0 μ f, 250, Normal Position	903300105	Nashville Elect.	8-250BP1- 25585 NP	*
C2	CAPACITOR, Dura Mica, 47 pf, ±5%, 500V	901900470	El-Menco	DM15-470J	*
C3	CAPACITOR, Ceramic Disc, .01, 150V	901440103	Centralab	DDM-103	*
C4	CAPACITOR, Dura Mica, 680 pf, ±5%, 500V	901900681	El-Menco	DM15-681J	2
L1	INDUCTOR, Variable	A01897400	Sierra	A01897400	*
Q1	TRANSISTOR, 2N2361, PNP	910300018	Philco	2N236	1
R1	RESISTOR, Fixed Composition, 270Ω, ±5%, 1/4W	906900271	Speer		*
R2	RESISTOR, Fixed Composition, 15K, ±5%, 15K	906900153	Speer		5
R3	RESISTOR, Fixed Composition, 22K, ±5%, 1/4W	906900223	Speer		*
R4	RESISTOR, Fixed Composition, 2700Ω, ±5%, 1/4W	906900272	Speer		*
R5	RESISTOR, Fixed Composition 560Ω, ±5%, 1/4W	906900561	Speer		*
XQ1	TRANSISTOR Socket, 4 Pin	914200037	Groyhill	22-16-4	*
	SECOND I.F. - B02050500				
C1	CAPACITOR, Ceramic Disc .1, 50V	901410104	Sprague	33C41	*
C2	CAPACITOR, Vert. Mounting, Plastic Encased, 1.0μf, 25V, Normal Position	903300105	Nashville Elect.	8-250P- 25585 NP	*
C3	CAPACITOR, Ceramic Disc .01, 150V	901440103	Centralab	DDM-103	*
C4	CAPACITOR, Dura Mica, 56 pf, 500V	901900560	El-Menco	DM15-560J	1
L1	INDUCTOR, Variable	A01897400	Sierra	A01897400	*
Q1	TRANSISTOR, 2N2360, PNP	910300017	Philco	2N2360	*
R1	RESISTOR, Fixed Composition, 8.2K, ±5%, 1/4W	906900822	Speer		1
R2	RESISTOR, Fixed Composition, 120Ω, ±5%, 1/4W	906900121	Speer		1
R3	RESISTOR, Fixed Composition, 47Ω, ±5%, 1/4W	906900470	Speer		*
R4	RESISTOR, Fixed Composition, 470Ω, ±5%, 1/4W	906900471	Speer		2
R5	Same as R4				
R6	RESISTOR, Fixed Composition, 12K, ±5%, 1/4W	906900123	Speer		*
R7	RESISTOR, Fixed Composition, 560Ω, ±5%, 1/4W	906900561	Speer		1
XQ1	TRANSISTOR Socket, 4 Pin	914200037	Groyhill	22-16-4	*
	ATTENUATOR - D01987000				
C1	CAPACITOR, Part of Attenuator Assembly		Sierra	C01989300	8
C	CAPACITOR, Button Mica, 100 pf, ±5%	901800101	Erie	2930-004	9
C3	Same as C1				
C4	Same as C2				
C5	Some as C1				
C6	Some as C2				
C7	Some as C1				
C8	Some as C2				

*Previously Accounted For

MODEL 128A

Section V

REPLACEABLE PARTS LIST

Schem. Ref. No.	Description	Sierra Stock No.	Mfr.	Dwg. or Mfr. No.	Tot. Quan.
C9	Some as C1				
C10	Some as C2				
C11	Some as CJ				
C12	Some as C2				
C13	Same as C1				
C14	Same as C2				
C15	CAPACITOR, Gloss Piston, .7-14pf	903000120	JFD	VC-11G	8
C 16	Some as C2				
C17	Some as C15				
C1B	Same as C2				
C19	Same as C15				
C20	CAPACITOR, Button Mica, 68 pf, ±5%	901800680	Erie	2930-004	2
C21	CAPACITOR, Gloss Piston, 1-60 pf	903000600	JFD	B01985500	1
C22	Some as C20				
C23	Same as C1				
C24	CAPACITOR., Silver Mica, 47 pf, 500V	902010470	El-Menco	CM15E470J	1
C25	CAPACITOR, Silver Mica, 120 pf, ±5%, 500V	902010121	El-Menco	CM15E121J	1
C26	CAPACITOR, Silver Mica, 5 pf, ±20%, 500V	902040050	El-Menco	CM15C050M	*
C27	Same as C15				
C28	CAPACITOR, Silver Mica, 22 pf, ±2%, 500V	902070220	El-Menco	CM15C220G	1
C29	Same as C15				
C30	CAPACITOR, Silver Mica, 68 pf, ±5%, 500V	902010680	El-Menco	CM15E680J	1
C31	Same as C15				
C32	CAPACITOR, Feed Thru, 1000 pf, 500V	902640102	Erie	1200-052	*
C33	Same as C32				
C34	Same as C32				
J1A	CONNECTOR, GR	914600095	General Radio	874-PRLT	1
J1B	Connector Adapter to BNC	914600089	General Radio	874-QBL	1
	Optional Connector W. E. Type		Sierra	B022031	
L1	INDUCTOR, Fixed, 82 µh	909000124	Delevan	1537-72	4
R1	RESISTOR, Metal Film, ±1%, 75Ω, 1W, 50 PPM	907600013	Electro	MF1	1
R2	RESISTOR, Metal Film, ±1%, 135Ω, 1W, 50 PPM	907600012	Electra	MF1	1
R3	RESISTOR, Metal Film, ±1%, 600Ω, 1W, 50 PPM	907600011	Electra	MF1	1
R4	RESISTOR, Fixed Composition, 22Ω, ±5%, 1/4W	906900220	Speer		*
R5	Same as R4				
R6	RESISTOR, Fixed Composition, 82Ω, ±5%, 1/4W	906900820	Speer		2
R7	RESISTOR, Fixed Composition, 33Ω, ±5%, 1/4W (Nominal value, may be factory selected)	906900330	Speer		1
S2	SWITCH Detent for S2	911200094	Oak	A01897100	1
		911200103	Oak	A01896200	1
S3	SWITCH	911200088	Oak	A01896400	1
S4A	SWITCH	911200102	Oak	A01990400	1
S4BC	SWITCH	911200087	Oak	A01896300	1
	PREAMPLIFIER- B02163000				
C1	CAPACITOR, Disc Ceramic, 0.1 µf, 50V	901410104	Sprague	33C41	*
C2	Same as C1				
C3	Some as C1				
C4	CAPACITOR, 22 µf, 25V, Normal Position, Vertical Mounting, Plastic Encased	903300226	Nashville Elect.	16-375BP22- 25585NP	*
C5	CAPACITOR, 10 µf, 25V, Normal Position, Vertical Mounting, Plastic Encased	903300106	Nashville Elect.	12-375BP10- 25S85NP	*

*Previously Accounted For

MODEL 128A

Section V

REPLACEABLE PARTS LIST

Schem. Ref. No.	Description	Sierra Stock No.	Mfr.	Dwg. or Mfr. No.	Tot. Quan.
C6	Same as C4				
C7	CAPACITOR, Dura Mica, 100 pf, ±5%, 500V	901900101	El-Menco	DM15-10IJ	3
C8	CAPACITOR, Max-C Trimmer Sealcap 1-60 pf	903010600	JFD	MC-6Z6Y	1
L1	INDUCTOR, Fixed 4.7 µh	909000123	Delevan		1
Q1	TRANSISTOR, NPN	910300038	Fairchild 2N2483		2
Q2	Same as Q1				
Q3	TRANSISTOR, NPN	910300024	Fairchild 2N706B		3
R1	RESISTOR, Fixed Comp. 22 Meg, ±5%, 1/4W	906900226			1
R2	RESISTOR, Fixed Comp. 47K, ±5%, 1/4W	906900473			*
R3	RESISTOR, Fixed Comp. 2.2 Meg, ±5%, 1/4W	906900225 1			1
R4	RESISTOR, Fixed Comp. 1.5K, ±5%, 1/4W	906900152			*
R5	RESISTOR, Fixed Comp. 150 Ohm, ±5%, 1/4W	906900151			*
R6	RESISTOR, Fixed Comp. 47 Ohm, ±5%, 1/4W	906900470			*
R7	Same as R6				*
R8	RESISTOR, Fixed Comp. 680 Ohm, ±5%, 1/4W	906900681			*
XQ1	TRANSISTOR, Socket, 3 Pin	914200036	Grayhill	22-16-3	*
XQ2	Same as XQ1				
XQ3	Same as XQ1				
	GAIN REFERENCE - B01999500				
C1	CAPACITOR, 1 µf Disc Ceramic, 50V	901410104	Sprague	33C41	*
C2	Same as C1				
C3	Same as C1				
C4	Same as C1				
C5	CAPACITOR, Vertical Mounting, Plastic Encased, 10 µf, 25 V, NP	903300106	Nashville Electronics	12-375BP10-25S85NP	*
C6	CAPACITOR, Dura Mica, 1500 pf, ±5%, 500V	901910152	El-Menco	DM19-152J	*
C7	CAPACITOR, Dura Mica, 330 pf, ±5%, 500 V	901910331	El-Menco	DM19-302J	9
C8	Same as C1				
C9	Same as C1				
CR1	DIODE, Silicon, S10G	910500010	Transitron	S10G	5
L1	INDUCTOR, 10 µh, ±10%, Molded	909000125	Delevan	1537-36	1
L2	INDUCTOR, 24 µh, Molded	909000121	Delevan	1537-46	*
L3	Same as L2				
L4	INDUCTOR, Variable	A01897400	Sierra	A01897400	*
Q1	TRANSISTOR, NPN	910300026	Fairchild	2N2368	1
Q2	TRANSISTOR, PNP	910300017	Philco	2N2360	*
Q3	TRANSISTOR, NPN	910300022	Motorola	2N706A	*
R1	RESISTOR, Fixed Composition, 1000 Ω, ±5%, 1/4W	906900102			*
R2	RESISTOR, Fixed Composition, 1500Ω, ±5%, 1/4W	906900152			*
R3	RESISTOR, Fixed Composition, 680Ω, ±5%, 1/4W	906900681			6
R4	RESISTOR, Fixed Composition, 3300Ω, ±5%, 1/4W	906900332			*
R5	RESISTOR, Fixed Composition, 2200Ω, ±5%, 1/4W	906900222			*
R6	RESISTOR, Fixed Composition, 560Ω, ±5%, 1/4W	906900561			*
R7	RESISTOR, Fixed Composition, 33K, ±5%, 1/4W	906900333			*
R8	RESISTOR, Fixed Composition, 3900Ω, ±5%, 1/4W	906900392			*
R9	RESISTOR, Fixed Composition, 15K, ±5%, 1/4W	906900153			*

*Previously Accounted For

MODEL 128A

Section V

REPLACEABLE PARTS LIST

Schem. Ref. No.	Description	Sierra Stock No.	Mfr.	Dwg. or Mfr. No.	Tot. Quan.
XQ1	TRANSISTOR SOCKET, 3 pin	914200036	Grayhill	22-16-3	*
XQ2	TRANSISTOR SOCKET, 4 pin	914200037	Grayhill	22-16-4	*
XQ3	Same as XQ1				
XY1	SOCKET, Crystal	914200007	Miller	33302	*
Y1	CRYSTAL, 1.000 mc	912200026	Wright	A01896600	1
	OUTPUT AMPLIFIER - SA0571281 (B02051000)				
C1	CAPACITOR, Disc Ceramic, 0.1 µf, 50V	901410104	Sprague	33C41	*
C2	CAPACITOR, Disc Ceramic, .01 µf, 150V	901440103	Centralab	DDM- 103	*
C3	Same as C1				
C4	Same as C2				
C5	CAPACITOR, Tubular Ceramic, 47 pf, N750	901420470	Centralab	TCN-47	1
C6	CAPACITOR, Dura Mica, 1200 pf, ± 5%, 500V	901900122	El-Menco	DM19-122J	2
C7	Same as C2				
C8	Same as C1				
C9	CAPACITOR, Tubular Ceramic, 82 pf, N750	901400820	Centralab	TCN-82	1
C10	CAPACITOR, Dura Mica, 100 pf, ±5%, 500V	901900101	El-Menco	DM15-IOIJ	2
C11	CAPACITOR, Feed Thru, 1000 pf, 500V	902640102	Erie	1200-052	*
C12	Same as C2				
C13	Same as C2				
C14	CAPACITOR, Dura Mica, 220 pf, ±5%, 500V	901900221	El-Menco	DM15-221J	3
C15	Same as C2				
C16	Same as C1				
C17	Same as C2				
C18	Same as C1				
C19	Same as C2				
C20	Same as C2				
C21	Same as C1				
C22	Some as C1				
C23	Same as C1				
C24	Same as C1				
C25	Same as C1				
C26	Same as C2				
CR1	DIODE, Silicon, S10G	910500010	Transitron	S10G	*
CR2	Same as CR				
J5	JACK, Phone 3/8" Bushing, Single Ckt. Norm Closed	914400016	Switchcraft	L-12A	1
P29	CABLE ASSEMBLY		Sierra	B02052004	1
P24	CABLE ASSEMBLY		Sierra	B02084401	*
K1	RELAY, Type 4	912600028	Phillips	4CQA164E	1
L1	INDUCTOR, Variable	A01897400	Sierra	A01897400	*
L2	Some as L1				
L3	INDUCTOR, Fixed, 24 µh, Molded	909000121	Delevan	1537-46	*
L4	INDUCTOR, Fixed, 3.3 mh	909000116	J.W. Miller	70F33A1	*
L5	Same as L4				
L6	Same as L4				
L7	Same as L4				
L8	Same as L4				

*Previously Accounted For

MODEL 128A

Section V

REPLACEABLE PARTS LIST

Schem. Ref. No.	Description	Sierra Stock No.	Mfr.	Dwg. or Mfr. No.	Tot. Quan.
M1	METER, Tautband, 200 µa Movement	911800060	API, Weston	A01895700	1
Q1	TRANSISTOR, PNP, 2N2360	910300017	Philco	2N2360	*
Q2	Same as Q1				
Q3	TRANSISTOR, PNP, 2N1745	910300020	Philco	2N1745	*
Q4	Same as Q3				
Q5	Same as Q3				
R1	RESISTOR, Fixed Composition, 470Ω, ±5%, 1/4W	906900471	Speer		4
R2	RESISTOR, Fixed Composition, 4700Ω, ±5%, 1/4W	906900472	Speer		*
R3	RESISTOR, Fixed Composition, 680Ω, ±5%, 1/4W	906900681	Speer		*
R4	RESISTOR, Variable, 25 Turn, 500Ω	907900102	AB		*
R5	RESISTOR, Fixed Composition, 100Ω, ±5%, 1/4W	906900101	Speer		*
R6	RESISTOR, Fixed Composition, 56K, +5%, 1/4W	906900563	Speer		*
R7	RESISTOR, Fixed Composition, 33K, ±5%, 1/4W	906900333	Speer		*
R8	RESISTOR, Fixed Composition, 6800Ω, ±5%, 1/4W	906900682	Speer		*
R9	RESISTOR, Fixed Composition, 68Ω, +5%, 1/4W	906900680	Speer		*
R10	RESISTOR, Fixed Composition, 27K, +5%, 1/4W	906900273	Speer		4
R11	Same as R6				
R12	Same as R8				
R13	RESISTOR, Fixed Composition, 10Ω, +5%, 1/4W	906900100	Speer		*
R14	RESISTOR, Fixed Composition, 47K, ±5%, 1/4W	906900473	Speer		*
R15	Same as R10				
R16	RESISTOR, Fixed Composition, 1000Ω, ±5%, 1/4W	906900102			2
R17	RESISTOR, Fixed Composition, 18K, ±5%, 1/4W	906900183	Speer		4
R18	Same as R6				
R19	RESISTOR, Variable, 1000Ω, Type UPE-70, ±20%	907900105	CTS	CTS 32275	1
R20	RESISTOR, Fixed Composition, 560Ω, ±5%, 1/4W	906900561	Speer		*
R21	Same as R16				
R22	Same as R3				
R23	RESISTOR, Fixed Composition, 12K, +5%, 1/4W	906900123	Speer		*
R24	Same as R14				
R25	Same as R20				
R26	RESISTOR, Fixed Composition, 1800Ω, ±5%, 1/4W	906900182	Speer		3
R27	RESISTOR, Fixed Composition, 5600Ω, ±5%, 1/4W	906900562	Speer		*
R28	Same as R27				
R29	Same as R23				
R30	Same as R26				
R31	RESISTOR, Fixed Composition, 2200Ω, ±5%, 1/4W	906900222	Speer		*
R32	RESISTOR, Fixed Composition, 180Ω, ±5%, 1/4W	906900181	Speer		*
R33	Same as R27				
R34	POTENTIOMETER, 2W, 25004, 10%, Linear Series HT321	907900152	CTS	35774	1
RT1	THERMISTOR, 150Ω, Disc Type	913600009	Fenwal	KB21L2	1
XQ1	SOCKET, Transistor, 4 Pin	914200037	Grayhill	22-16-4	*
XQ2	Same as XQ1				
XQ3	SOCKET, Transistor, 3 Pin	914200036	Grayhill	22-16-3	*
XQ4	Same as XQ3				
XQ5	Same as XQ3				
K1	RELAY, 1500Ω, 5.8 ma, P.C. Mtg., SPDT(Main Lock Indicator relay mounted on Output Amplifier cover.)	912600026	Sigma	11PF1500G-SIL	3

*Previously Accounted For

MODEL 128A

Section V

REPLACEABLE PARTS LIST

Schem. Ref. No.	Description	Sierra Stock No.	Mfr.	Dwg. or Mfr. No.	Tot. Quan.
	MAIN TUNING (MODE SWITCH) - B02001500				
J14	CONNECTOR, 930, Screw Type P.C. Mounting	914600086	Microdot	31-67	3
J15	Same as J14				
J16	Some as J14				
μ					
R1	RESISTOR, Fixed Composition, 10K, ± 5%, 1/4W	906900103	Speer		*
R2	RESISTOR, Variable, 10K, 25 Turn, Type R	907900172	AB	RP-103U	2
S5	SWITCH, 2 Pole, 2 Pos., Type 22	911200099	Oak	B01893600	1
	INCREMENTAL TUNING OSCILLATOR - B02001600				
C1	CAPACITOR, Tubular Ceramic, 10 pf, N330	901430100	Centralab	TCA10	1
C2	CAPACITOR, Tubular Ceramic, 39 pf, N150	901420390	Centralab		1
C3	CAPACITOR, Tubular Ceramic, 150 pf, NPO	901400151	Centralab	TCZ150	2
C4	CAPACITOR, Dura Mica, 1500 pf, ±5%, 500V	901910152	El-Menco	DM19-152J	*
C5	CAPACITOR, Tubular Ceramic, 39 pf, NPO	901410390	Centralab	TCZ39	1
C6	CAPACITOR, Glass Piston .7-14pf	903000120	JFD	VC-I1G	*
C7	CAPACITOR, Vertical Mounting, Plastic Encased, 10μf, 25V, Normal Position	903300106	Nashville Elect.	12-375BP10-25S85 NP	*
C8	CAPACITOR, Dura Mica, 4700 pf, ±5%, 500V	901900472	EL-Menco	DM19-472J	1
C9	CAPACITOR, Disc Ceramic, .01 μf, 150V	901440103	Centralab	DDM-103	*
C10	CAPACITOR, Disc Ceramic, 0.1 μf, 50V	901410104	Sprague	33C41	*
C11	Some as C9				
L1	INDUCTOR, Variable	A01897300	Sierra	A01897300	1
Q1	TRANSISTOR, NPN	910300022	Motorola	2N706A	*
R1	RESISTOR, Fixed Composition, 8200Ω, ±5%, 1/4W	906900822	Speer		*
R2	RESISTOR, Fixed Composition, 82K, ±5%, 1/4W	906900823	Speer		1
R3	RESISTOR, Fixed Composition, 12K, ±5%, 1/4W	906900123	Speer		*
R4	RESISTOR, Fixed Composition, 1000Ω, ±5%, 1/4W	906900102	Speer		*
R5	RESISTOR, Fixed Composition, 390Ω, ±5%, 1/4W	906900391	Speer		5
R6	RESISTOR, Fixed Composition, 100K, ±5%, 1/4W	906900104	Speer		*
R7	Some as R4				
XQ1	SOCKET, Transistor, 3 pin	914200036	Grayhill	22-16-3	*
	INCREMENTAL TUNING CASTING - B02063500				
C1	CAPACITOR, Variable Air, 50-450 pf	902800451	Radio Condenser Co.	A01a95800	1
DS2	LAMP, Indicator, Amber	913800040	Cal-Glo	75AS	2
J3	CONNECTOR, BNC Panel, UG-1094/U	914600035	Amphenol	74868	2
J18	CONNECTOR, Screw Type, Bulkhead	914600099	Amp	329852	*
J19	Same as J18				
J20	Same as J18				
R1	RESISTOR, Variable, 20K	907900181	Circuitrim		1
TP7	JACK, Tip, Insulated, Yellow Nylon	914400007	Johnson		2

*Previously Accounted For

MODEL 128A

Section V

REPLACEABLE PARTS LIST

Schem. Ref. No.	Description	Sierra Stock No.	Mfr.	Dwg. or Mfr. No.	Tot. Quan.
	FIRST L.F. AMPLIFIER - B02044400				
C1	CAPACITOR, Vert. Mtg., Plastic Encased, 22µf, 25V	903300226	Nashville Elec.		*
C2	CAPACITOR, Disc Ceramic, .1 µf, 50V	901410104	Sprague	33C41	*
C3	Some as C2				
C4	CAPACITOR, .01µf, 150V	901440103	Centralab	DDM-103	*
C5	CAPACITOR, 22pf, ±5%, Dura Mica	901900221	El-Menco	DM15-221J	*
C6	Not used				
K1	RELAY, 1500 Ω, 5.8modc, P.C. Mtg. SPDT 1A Contacts	912600026	Sigma	11FP-1500G-SIL	*
L1	INDUCTOR, Fixed, 3.3 mh	909000116	J.W. Miller	70F333A	*
L2	INDUCTOR, Fixed 82 µh	909000124	Delevan	1537-72	*
Q1	TRANSISTOR, 2N1728, PNP	910300008	Philco	2N1728	*
Q2	Same as Q1				
Q3	TRANSISTOR, 2N414, PNP	910300004	Raytheon	2N414	*
R1	RESISTOR, Variable, 100K, ±20%, Type UPE-70	907900173	CTS	CTS 35442	1
R2	RESISTOR, Fixed Composition, 2.2K, ±5%, 1/4W	906900222	Speer		*
R3	RESISTOR, Fixed Composition, 39K, ± 5%, 1/4W	906900393	Speer		*
R4	RESISTOR, Fixed Composition, 150Ω ±5%, 1/4W	906900151	Speer		*
R5	RESISTOR, Fixed Composition, 56Ω, ±5%, 1/4W	906900560	Speer		1
R6	RESISTOR, Fixed Composition, 3.9K, ±5%, 1/4W	906900392	Speer		2
R7	RESISTOR, Fixed Composition, 33K, ±5%, 1/4W	906900333	Speer		*
R8	RESISTOR, Fixed Composition, 12K, ±5%, 1/4W	906900123	Speer		*
R9	Same as R6				
R10	RESISTOR, Fixed Composition, 470Ω, ±5%, 11/4W	906900471	Speer		*
R11	Not used				
R 12	Not used				
R13	Not used				
XQ1	TRANSISTOR, Socket, 3 Pin	914200036	Grayhill	22-16-3	*
XQ2	Same as XQ1				
XQ3	Same as XQ1				
	SECOND OSCILLATOR - B02044600				
C1	CAPACITOR, .01 Disc Ceramic, 150V	901440103	Centralab	DDM-103	*
C2	CAPACITOR, Tubular Ceramic, 10 pf, NPO	901420100	Centralab	TCZ10	1
C3	CAPACITOR, Tubular Ceramic, 30 pf, N750	901420300	Centralab	TCZ33	1
C4	CAPACITOR, Tubular Ceramic, 150 pf, NPO	901400151	Centralab	TCZ150	*
CS	CAPACITOR, Tubular Ceramic, 120 pf, NPO	901410121	Centralab	TCZ120	1
C6	Same as C1				
C7	Same as C1				
C8	CAPACITOR, Dura Mica, 56 pf, ±5%, 500V	901900560	El-Menco	DM15-560J	3
C9	Some as C1				
C10	CAPACITOR, Dura Mica, 10 pf, ±5%, 500V	901900100	El-Menco	DM15-100J	2
C11	Same as C1				
C12	Same as C1				
CR1	VARICAP, V10 (Varactor Diode)	913600010	PSI	V10	2
L1	INDUCTOR, Variable Glass, 2.15-2.35 µh	909400051	JFD	LVJ383 A3	1

*Previously Accounted For

MODEL 128A

Section V

REPLACEABLE PARTS LIST

Schem. Ref. No.	Description	Sierra Stock No.	Mfr.	Dwg. or Mfr. No.	Tot. Quan.
Q1	TRANSISTOR, 2N706B, NPN	910300024	Fairchild	2N706B	*
Q2	TRANSISTOR, 2N1745, PNP	910300020	Philco	2N1745	*
Q3	Some as Q2				
R1	RESISTOR, Fixed Composition, 39K, ±5%, 1/4W	906900393	Speer		*
R2	RESISTOR, Fixed Composition, 5.6K, ±5%, 1/4W	906900563	Speer		*
R3	RESISTOR, Fixed Composition, 120K, ±5%, 1/4W	906900124	Speer		*
R4	Same as R3				
R5	RESISTOR, Fixed Composition, 680Ω, ±5%, 1/4W	906900681	Speer		*
R6	RESISTOR, Fixed Composition, 390Ω, ±5%, 1/4W	906900391	Speer		*
R7	RESISTOR, Fixed Composition, 12K, ±5%, 1/4W	906900123	Speer		*
R8	RESISTOR, Fixed Composition, 10K, ±5%, 1/4W	906900103	Speer		*
R9	RESISTOR, Fixed Composition, 1000Ω, +5%, 1/4W	906900102	Speer		*
R10	RESISTOR, Fixed Composition, 180Ω, ±5%, 1/4W	906900181	Speer		*
R11	RESISTOR, Fixed Composition, 27K, ±5%, 1/4W	906900273	Speer		*
R12	Same as R11				
R13	RESISTOR, Fixed Composition, 3300Ω, +5%, 1/4W	906900332	Speer		*
XQ1	TRANSISTOR, Socket, 3 Pin	914200036	Grayhill	22-16-3	*
XQ2	Same as XQ1				
XQ3	Some as XQ1				
	INCREMENTAL REFERENCE OSCILLATOR & MIXER B02045000				
C1	CAPACITOR, .01 Disc Ceramic, 150V	901440103	Centralab DOM-	103	*
C2	Same as C1				
C3	CAPACITOR, Variable Ceramic, 2-8 pf, PC Mtg.	903200080	Erie	538-011-89R	3
C4	CAPACITOR, Tubular Ceramic, 100 pf, NPO	901420101	Centralab	TCZ100	*
C5	Same as C1				
C6	CAPACITOR, Tubular Ceramic, 22 pf, NPO	901420220	Centralab	TCZ22	1
C7	CAPACITOR, Tubular Ceramic, 47 pf, NPO	901410470	Centralab	TCZ47	1
C8	CAPACITOR, 0.1 Disc Ceramic, 50V	901410104	Sprague	33C41	*
C9	CAPACITOR, Dura Mica, 5 pf, 500V	901900050	El-Menco	DM15-050K	1
C10	CAPACITOR, Variable, Glass, .8-.5 pf	903000885	Erie	563-013	2
C11	CAPACITOR, Dura Mica, 330pf, 500V	901900331	El-Menco	DM15-331J	5
C12	Same as C11				
C13	Same as C11				
C14	Same as C10				
C15	Same as C11				
C16	Same as C11				
CR1	DIODE, Matched Pair, MP3507	910500009	Rheem	AH1043	3
CR2	Part of CR1				
L1	INDUCTOR, Fixed, 24 μh, Molded	909000121	Delevan	1537-46	*
L2	INDUCTOR, Variable, Gloss, 1.05 μh Nominal	909400053	JFD	LV5P102	1
Q1	TRANSISTOR, 2N706A, NPN	910300022	Motorola	2N706A	*
Q2	TRANSISTOR, 2N1745	910300020			*
R1	RESISTOR, Fixed Composition, 680Ω, ±5%, 1/4W	906900681	Speer		*
R2	RESISTOR, Fixed Composition, 15K, ±5%, 1/4W	906900153	Speer		*

*Previously Accounted For

MODEL 128A

Section V

REPLACEABLE PARTS LIST

Schem. Ref. No.	Description	Sierra Stock No.	Mfr.	Dwg. or Mfr. No.	Tot. Quan.
R3	RESISTOR, Fixed Composition, 22K, ±5%, 1/4W	906900223	Speer		*
R4	RESISTOR, Fixed Composition, 2700Ω, ±5%, 1/4W	906900272	Speer		*
R5	RESISTOR, Fixed Composition, 10K, ±5%, 1/4W	906900103	Speer		*
R6	RESISTOR, Fixed Composition, 220Ω, ±5%, 1/4W	906900221	Speer		*
R7	RESISTOR, Variable, 500Ω, 25 Turn, Type R	907900102	AB		*
R8	Same as R5				
R9	Same as R6				
R10	RESISTOR, Fixed Composition, 1.8K, ±5%, 1/4W	906900182	Speer		*
R11	Same as R2				
R12	RESISTOR, Fixed Composition, 18K, ±5%, 1/4W	906900183	Speer		*
R13	RESISTOR, Fixed Composition, 470Ω, ±5%, 1/4W	906900471	Speer		*
T1	TRANSFORMER, 1:1 Ct. Sec.	C01921400	Sierra	C01921400	*
XQ1	SOCKET, Transistor, 3 Pin	914200036	Grayhill		*
XQ2	Same as XQ1				
XY1	SOCKET, Crystal	914200007	James Millen Mfg. Co.	33302	*
Y1	CRYSTAL, 18.585 Mc	912200027	Bliley	A01896100	1
	SECOND L.F. AMPLIFIER - B02002000				
C1	CAPACITOR, .01 Disc Ceramic, 150V	901440103	Centralab	DDM-103	*
C2	CAPACITOR, Dura Mica, 150pf, ±5%, 500V	901900151	El-Menco	DMI5-151J	2
C3	Some as C1				
C4	CAPACITOR, 0.1 μf, Disc Ceramic, 50V	901410104	Sprague	33C41	*
C5	CAPACITOR, Dura Mica, 120 pf, ±5%, 500V	901900121	El-Menco	DM15-121J	1
C6	Some o C4				
C7	CAPACITOR, 10 μf, 25V, Normal Position, Vertical Mounting, Plastic Encased	903300106	Nashville Elect.	12-375BP10-25S85 NP	*
L1	INDUCTOR, 83 μh, Molded	909000124	Delevan	1537-72	*
Q1	TRANSISTOR, 2N1728, PNP	910300008	Philco	2N1728	*
Q2	TRANSISTOR, 2N414, PNP	910300004	Raytheon	2N414	*
R1	RESISTOR, Fixed Composition, 4700Ω, ±5%, 1/4W	906900472	Speer		*
R2	RESISTOR, Fixed Composition, 39K, ±5%, 1/4W	906900393	Speer		*
R3	RESISTOR, Variable, 500Ω, Type UPE-70	907900174	CTS		2
R4	RESISTOR, Fixed Composition, 2700Ω, ±5%, 1/4W	906900272	Speer		*
R5	Sam as R1				
R6	RESISTOR, Fixed Composition, 3900Ω, ±5%, 1/4W	906900392	Speer		*
R7	RESISTOR, Fixed Composition, 560Ω, ±5%, 1/4W	906900561	Speer		*
XQ1	TRANSISTOR Socket, 3 Pin	914200036	Grayhill	22-16-3	*
XQ2	Same as XQ1				

*Previously Accounted For

MODEL 128A

Section V

REPLACEABLE PARTS LIST

Schem. Ref. No.	Description	Sierra Stock No.	Mfr.	Dwg. or Mfr. No.	Tot. Quan.
	PHASE DISCRIMINATOR - B02002100				
C1	CAPACITOR, Dura Mica, 2000 pf, 500V	901900202	El-Menco	DM19-202J	2
C2	Same as C1				
C3	CAPACITOR, 0.1 Disc Ceramic, 50V	901410104	Sprague	33C41	*
C4	Same as C3				
C5	Same as C3				
C6	CAPACITOR, .01 Disc Ceramic, 150V	901440103	Centralab	DDM-103	*
C7	Same as C6				
CR1	DIODE, Matched Pair, MP3507	910500009	Rheem	AH1043	*
CR2	Part of CR1				
CR3	DIODE, S555G	910500003	Transitron	S555G	3
CR4	Same as CR3				
L1	INDUCTOR, 640 µh, Vert. P.C. Mounting	A01920100	Sierra	A01920100	1
R1	RESISTOR, Fixed Composition, 390Ω, ±5%, 1/4W	906900391	Speer		*
R2	RESISTOR, Fixed Composition, 1200Ω; ±5%, 1/4W	906900122	Speer		3
R3	RESISTOR, Fixed Composition, 120K, ±5%, 1/4W	906900124	Speer		*
R4	RESISTOR, Fixed Composition, 10K, ±5%, 1/4W	906900103	Speer		*
R5	RESISTOR, Variable, 10K, 25 Turn, Type R	907900172	AB	RP-103U	*
R6	Same as R4				
T1	TRANSFORMER, 1:10, Center Tapped Sec.	909900016	Pulse Eng.	PE5643	1
T2	TRANSFORMER, 1:4	909900017	Pulse Eng.	PE5667	1
	LOW-PASS FILTER 125 kc - B02002200				
C1	CAPACITOR, Dura Mica, 56pf, ±5%	901900560	El-Menco	DM15-560J	*
C2	CAPACITOR, Dura Mica, 180 pf, ±5%	901900181	El-Menco	DM15-181J	2
C3	CAPACITOR, 1.0µf, 25V, Plastic enc. Vert Mtg. NP	903300105	Nashville Elec.	8-250BP1	1
C4	CAPACITOR, Dura Mica, 390pf, ±5%	901900391	El-Menco	DM15-391J	*
C5	CAPACITOR, Dura Mica, 22 pf, ±5%	901900220	El-Menco	DM15-220J	*
C6	Same as C4				
C7	Same as C5				
C8	Same as C1				
C9	Same as C2				
L1	INDUCTOR, Fixed, 10.5 mh	A02001200	Sierra	A02001200	2
L2	INDUCTOR, Fixed, 13.5 mh	A01896700	Sierra	A01896700	1
L3	Same as L1				
R1	RESISTOR, Fixed Composition, 5600Ω, ±5%, 1/4W	906900562	Speer		*

*Previously Accounted For

MODEL 128A

Section V

REPLACEABLE PARTS LIST

Schem. Ref. No.	Description	Sierra Stock No.	Mfr.	Dwg. or Mfr. No.	Tot. Quan.
	INCREMENTAL LOCK INDICATOR - B02002300				
C1	CAPACITOR, 22 mfd, 25V, Normal Position, Vertical Mounting, Plastic Encased	903300226	Nashville Elect.	16-375BP22-25S85 NP	*
C2	CAPACITOR, 0.1, Disc Ceramic, 50V	901410104	Sprague	33C41	*
C3	Some as C1				
C4	Some as C2				
C5	CAPACITOR, 1.0 mfd, 25V, Normal Position, Vertical Mounting, Plastic Encased	903300105	Nashville Elect.	8-25OBPI-25S85 NP	*
CR1	DIODE, Silicon S10G	910500010	Transitron	S10G	*
K1	RELAY, 1500Ω, 5.8 madc, P.C. Mounting, SPDT 1a Contacts	912600026	Sigma	11FP-1500G-SIL	*
Q1	TRANSISTOR, 2N706A, NPN	910300022	Motorola	2N706A	*
Q2	Some as Q1				
Q3	Same as Q1				
R1	RESISTOR, Fixed Composition, 220K, ±5%, 1/4W	906900224	Speer		*
R2	RESISTOR, Fixed Composition, 3300Ω, ±5%, 1/4W	906900332	Speer		*
R3	RESISTOR, Fixed Composition, 6800Ω, ±5%, 1/4W	906900682	Speer		*
R4	RESISTOR, Fixed Composition, 1200Ω, ±5%, 1/4W	906900122	Speer		*
R5	RESISTOR, Fixed Composition, 1500Ω, ±5%, 1/4W	906900152	Speer		*
R6	RESISTOR, Fixed Composition, 150Ω, ±5%, 1/4W	906900151	Speer		*
R7	RESISTOR, Fixed Composition, 18K, ±5%, 1/4W	906900183	Speer		*
R8	RESISTOR, Fixed Composition, 8200Ω, ±5%, 1/4W	906900822	Speer		*
XQ1	TRANSISTOR Socket, 3 Pin	914200036	Grayhill	22-16-3	*
XQ2	Some as XQ1				
XQ3	Some as XQ1				
	MAIN TUNING CASTING - B02063600				
C1	CAPACITOR, Variable Air, 7-75 pf	902810750	Hammorlund	9420-17-1003	1
DS1	LAMP, Indicator Amber	914200040	Coa-Glo	75AS	*
J2	CONNECTOR, BNC Panel, UG-1094/U	914600035	Amphenol	74868	*
J8	CONNECTOR, Screw Type, Bulkhead	914600099	Amp	329852	*
J9	Same as J8				
J10	Same as J8				
J11	Same as J8				
J12	Same as J8				
J13	Some as J8				
K1	RELAY, 2500Ω, DPDT	912600025	Sigma	42F2-2500S-SIL	1
TP6	JACK, Tip, Insulated, Yellow Nylon	914400007	Johnson		*

*Previously Accounted For

MODEL 128A

Section V

REPLACEABLE PARTS LIST

Schem. Ref. No.	Description	Sierra Stock No.	Mfr.	Dwg. or Mfr. No.	Tot. Quan.
	MAIN TUNING OSCILLATOR - B01999600				
C1	CAPACITOR, Vertical Mounting, Plastic Encased, 1.00 μ f, 25V, Normal Position	903300105	Nashville Elect.	8-250BP1-25585 NP	*
C2	CAPACITOR, Disc Ceramic, .01 μ f, 15V	901440103	Centralab	DDM-103	*
C3	Same as C2				
C4	Same as C2				
CS	Same as C2				
C6	CAPACITOR, Tubular Ceramic, 12 pf, N750	901420120	Centralab	TCN 12	1
C7	CAPACITOR, Tubular Ceramic, 6.8 pf, NPO	901400068	Centralab	TCZ 6R8	1
C8	CAPACITOR, Variable Glass, .7-14 pf	903000120	FD	VC-11G	*
C9	CAPACITOR, Tubular Ceramic, 100 pf, NPO	901420101	Centralab	TCZ 100	*
C10	CAPACITOR, Dura Mica, 27 pf, \pm 5%, 500V	901900270	EL-Menco	DM15-270J	1
C11	CAPACITOR, Dura Mica, 3 pf, 500V	901900030	EI-Menco	DM15-030K	1
C12	Same as C2				
C13	Same as C2				
CR1	VARICAP V10 (Varactor Diode)	913600010	PSI	V10	*
L1	INDUCTOR, Variable Glass	909400052	JFD	LV5P056	1
L2	INDUCTOR, Fixed Molded, 24 μ h	909000121	Delevon	1537-46	1
Q1	TRANSISTOR, NPN	910300024	Fairchild	2N7068	*
Q2	TRANSISTOR, PNP	910300017	Philco	2N2360	*
R1	RESISTOR, Fixed Composition, 100 Ω , \pm 5%, 1/4W	906900101	Speer		*
R2	RESISTOR, Fixed Composition, 39K, \pm 5%, 1/4W	906900393	Speer		*
R3	RESISTOR, Fixed Composition, 5600 Ω , \pm 5%, 1/4W	906900562	Speer		*
R4	RESISTOR, Fixed Composition, 680 Ω , \pm 5%, 1/4W	906900681	Speer		*
R5	RESISTOR, Fixed Composition, 4700 Ω , \pm 5%, 1/4W	906900472	Speer		*
R6	RESISTOR, Fixed Composition, 3300 Ω , \pm 5%, 1/4W	906900332	Speer		*
R7	RESISTOR, Fixed Composition, 22K, \pm 5%, 1/4W	906900223	Speer		*
R8	RESISTOR, Fixed Composition, 390 Ω , \pm 5%, 1/4W	906900391	Speer		*
R9	RESISTOR, Fixed Composition, 2200 Ω , \pm 5%, 1/4W	906900222	Speer		*
R10	Same as R8				
XQ1	SOCKET, Transistor, 3 Pin	914200036	Groyhill	22-16-3	*
XQ2	SOCKET, Transistor, 4 Pin	914200037	Grayhill	22-16-4	*
	MAIN TUNING FOLLOWER - B02044800				
C1	CAPACITOR, Dura Mica, 750 pf, \pm 5%, 300V	901900751	EI-Menco	DM1S-75J	1
C2	CAPACITOR, Disc Ceramic, 0.1 μ f, 50V	901410104	Sprague	33C41	*
C3	CAPACITOR, Vert. Mtg. Plastic Encared, 1.0 μ f, 25V, Normal Position	903300105	Nashville Elect.	8-250BPI-25S85 NP	*
C4	CAPACITOR, Dura Mica, 5 pf, 500V	901900050	EI-Menco	DM15-050K	*
C5	CAPACITOR, Disc Ceramic, .01 μ f, 1S0V	901440103	Centralab	DDM- 103	*
L1	INDUCTOR, Fixed, 680 μ h Molded	909000122	Delevon	4500-68	1
L2	INDUCTOR, Fixed, 3.3 mh	909000116	J.W. Miller	70F333A1	*
R1	RESISTOR, Fixed Composition, 12K, \pm 5%, 1/4W	906900123	Speer		*
R2	RESISTOR, Fixed Composition, 33K, \pm 5%, 1/4W	906900333	Speer		*
R3	RESISTOR, Fixed Composition, 1000 Ω , \pm 5%, 1/4W	906900102	Speer		*

*Previously Accounted For

MODEL 128A

Section V

REPLACEABLE PARTS LIST

Schem. Ref. No.	Description	Sierra Stock No.	Mfr.	Dwg. or Mfr. No.	Tot. Quan.
R4	RESISTOR, Fixed Composition, 68Ω, +5%, 1/4W	906900680	Speer		*
Q1	TRANSISTOR, NPN 2N706A	910300022	Motorola	2N706A	*
XQ1	SOCKET, Transistor, 3 Pin	914200036	Grayhill	22-16-3	*
	100KC OSCILLATOR & HARMONIC GENERATOR - B02002600				
C1	CAPACITOR, Vertical Mounting, Plastic Encased, 10 μ f, 25V, Normal Position	903300226	Nashville Elect.	16-375BP10- 25S85 NP	*
C2	CAPACITOR, Disc Ceramic, 0.1 μf, 50V	901410104	Sprague	33C41	*
C3	CAPACITOR, Variable Glass, .8-8.5 pf	903000885	Erie	563-013	*
C4	CAPACITOR, Dura Mica, 15 pf, ± 5%, 500V	901900150	El-Menco	DMI5-150J	*
Cs	CAPACITOR, Dura Mica, 1500 pf, ±5%, 500V	901910152	El-Menco	DMI9-152J	*
C6	CAPACITOR, Dura Mica, 560 pf, ±5%, 500V	901900561	El-Menco	DMS5-561J	2
C7	CAPACITOR, Dura Mica, 5600 pf, ±5%, 500V	901900562	El-Menco	DM19-562J	1
C8	CAPACITOR, Dura Mica, 330pf, ±5%, 500V	901900331	El-Menco	DM15-331J	*
C9	CAPACITOR, Dura Mica, 18 pf, ±5%, 500V	901900180	El-Menco	DM15-180J	1
C10	Sam as C1				
L1	INDUCTOR, Variable	A01897200	Sierra	A01897200	1
L2	INDUCTOR, Fixed, 82 μh, Molded	909000124	Delevan	1537-72	*
Q1	TRANSISTOR, NPN, 2N706A	910300022	Motorola	2N706A	*
Q2	Same as Q1				
Q3	Same as Q1				
Q4	Same as Q1				
R1	RESISTOR, Fixed Composition, 10K, ±5%, 1/4W	906900103	Speer		*
R2	Same as R1				
R3	RESISTOR, Fixed Composition, 4700Ω, ±5%, 1/4W	906900472	Speer		*
R4	RESISTOR, Fixed Composition, 82Ω, ±5%, 1/4W	906900820	Speer		*
R5	RESISTOR, Fixed Composition, 6800Ω, ±5%, 1/4W	906900682	Speer		*
R6	RESISTOR, Fixed Composition, 1000Ω ±5%, 1/4W	906900102	Speer		*
R7	RESISTOR, Fixed Composition, 1000Ω, ±5%, 1/2W	905000102	AB	EB	*
R8	RESISTOR, Fixed Composition, 12K, ±5%, 1/4W	906900123	Speer		*
R9	RESISTOR, Fixed Composition, 5600Ω, ±5%, 1/4W	906900562	Speer		*
R10	Same as R7				
R11	RESISTOR, Fixed Composition, 68Ω, ±15%, 1/4W	906900680	Speer		*
R12	RESISTOR, Fixed Composition, 47K, ±5%, 1/4W	906900473	Speer		*
R13	RESISTOR, Fixed Composition, 33K, ±5%, 1/4W	906900333	Speer		*
R14	RESISTOR, Fixed Composition, 3300Ω, ±5%, 1/4W	906900332	Speer		*
XQ1	SOCKET, Transistor, 3 Pin	914200036	Grayhill	22-16-3	*
XQ2	Same as XQ1				
XQ3	Same as XQ1				
XQ4	Same as XQ1				
Y1	CRYSTAL, 100.000 KC W/Wire Leads	912200030	Bliley	A01896000	1

*Previously Accounted For

MODEL 128A

Section V

REPLACEABLE PARTS LIST

Schem. Ref. No.	Description	Sierra Stock No.	Mfr.	Dwg. or Mfr. No.	Tot. Quan.
	MAIN TUNING MIXER - B02002700				
C1	CAPACITOR, .01 Disc Ceramic, 150V	901440103	Centralab	DDM-103	*
C2	CAPACITOR, Dura Mica, 100 pf, ± 5%, 500V	901900101	El-Menco	DM15-IOIJ	*
C3	CAPACITOR, Variable, Ceramic, 2-8 pf	903200080	Erie	538-011-89R	*
C4	CAPACITOR, Dura Mica, 220 pf, ±5%, 500V	901900221	EL-Menco	DM15-221J	*
C5	CAPACITOR, Dura Mica, 330 pf, ±5%, 500V	901900331	El-Menco	DM15-331J	*
C6	Same as C5				
C7	CAPACITOR, Dura Mica, 5 pf, 500V	901900050	El-Menco	DM15-050K	*
C8	Same as C3				*
C9	CAPACITOR, .1 Disc Ceramic, 50V	901410104	Sprague	33C41	*
CR1	DIODE, S555G	910500003	Transitron	S555G	*
CR2	DIODE, Matched Pair MP3507	910500033	Hughes	HD-1871E	*
CR3	Part of CR2				
Q1	TRANSISTOR, 2N2360 PNP	910300017	Philco	2N2360	*
R1	RESISTOR, Fixed Composition, 4700Ω, ±5%, 1/4W	906900472	Speer		*
R2	RESISTOR, Fixed Composition, 15K, ±5%, 1/4W	906900153	Speer		*
R3	RESISTOR, Fixed Composition, 680Ω, ±5%, 1/4W	906900681	Speer		*
R4	RESISTOR, Fixed Composition, 1000Ω, ±5%, 1/4W	906900102	Speer		*
R5	RESISTOR, Fixed Composition, 220Ω, ±5%, 1/4W	906900221	Speer		*
R6	RESISTOR, Fixed Composition, 10K, ±5%, 1/4W	906900103	Speer		*
R7	Same as R6				
R8	Same as R5				
R9	Same as R5				
R10	RESISTOR, Variable, 500Ω, Type UPE-70	907900174	CTS		*
T1	TRANSFORMER, 1:1, Center Tapped Sec.	C01921400	Sierra	C01921400	*
XQ1	TRANSISTOR Socket, 4 Pin	914200037	Grayhill	22-16-4	*
	LOW-PASS FILTER 50 kc, Input Stage - B02002900				
C1	CAPACITOR, Dura Mica, 560 pf, ±5%, 500V	901900561	El-Menco	DM15-561J	*
C2	CAPACITOR, Dura Mica, 150 pf, ±5%, 500V	901900151	El-Menco	DM15-151J	*
C3	CAPACITOR, Dura Mica, 1200 pf, ±5%,500V	901900122	El-Menco	DM19-122J	1
L1	INDUCTOR, Fixed, 16.9 mh	A01921300	Sierra	A01921300	1
	LOW-PASS FILTER 50 kc, Output Stage - B02003000				
C1	CAPACITOR, Dura Mica, 680 pf, ±5%, 500V	901900681	El-Menco	DM15-681J	*
C2	CAPACITOR, Vert. Mtg. Plastic Encesed, 22 μf,25V Normal Position	903300226	Nashville Elect.	16-3758P22-25585 NP	*
L1	INDUCTOR, Fixed, 23 mh	A01897600	Sierra	A01897600	1
L2	INDUCTOR, Fixed, 24 μh Molded	909000121	Delevan	1537-46	*
R1	RESISTOR, Fixed Composition,3900Ω, ±5%, 1/4W	906900392	Speer		*
R2	RESISTOR, Fixed Composition, 33K, ±5%, 1/4W	906900333	Speer		*

*Previously Accounted For

MODEL 128A

Section V

REPLACEABLE PARTS LIST

Schem. Ref. No.	Description	Sierra Stock No.	Mfr.	Dwg. or Mfr. No.	Tot. Quan.
	AMPLIFIER DETECTOR - B02002800				
C1	CAPACITOR, 22 µf, 25V, Normal Position, Vert. Mounting, Plastic Encased	903300226	Nashville Elect.	16-375BP22-25S85 NP	*
C2	CAPACITOR, Vert. Mounting, Plastic Encased, 10 µf, 25V, Normal Position	903300106	Nashville Elect.	12-375BP10-25S85 NP	*
C3	Same as C1				
C4	CAPACITOR, Dura Mica, 1200 pf, ±5%, 500V	901900122	El-Menco	DMI9-122J	*
C5	Same as C1				
C6	CAPACITOR, Disc Ceramic, 0.1, 50V	901410104	Sprague	33C41	*
L1	INDUCTOR, Fixed, 8.1 mh	A0189750C	Sierra	A01897500	1
L2	INDUCTOR, Fixed, 3.3 mh	909000116	J.W. Miller	70F333A1	*
Q1	TRANSISTOR, 2N1728 PNP	910300008	Philco	2N1728	*
Q2	Some as Q1				
Q3	TRANSISTOR. 2N414, PNP	910300004	Raytheon	2N414	*
R1	RESISTOR, Fixed Composition, 33K, ±5%, 1/4W	906900333	Speer		*
R2	RESISTOR, Fixed Composition, 39K, ±5%, 1/4W	906900393	Speer		*
R3	RESISTOR, Fixed Composition, 3300Ω, ±5%, 1/4W	906900332	Speer		*
R4	RESISTOR, Fixed Composition, 22K, ±5%, 1/4W	906900223	Speer		*
R5	Same as R2				
R6	RESISTOR, Fixed Composition, 2700Ω, ±5%, 1/4W	906900272	Speer		*
R7	RESISTOR, Fixed Composition, 1000Ω, ±5%, 1/4W	906900102	Speer		*
R8	RESISTOR, Fixed Composition, 470Ω, ±5%, 1/4W	906900471	Speer		*
R9	RESISTOR, Fixed Composition, 3900Ω, ±5%, 1/4W	906900392	Speer		*
R10	RESISTOR, Fixed Composition, 100Ω, ±5%, 1/4W	906900101	Speer		*
XQ1	TRANSISTOR, Socket, 3 Pin	914200036	Grayhill	22-16-3	*
XQ2	Same as XQ1				
XQ3	Same as XQ1				
	MAIN LOCK INDICATOR - B02003100				
C1	CAPACITOR, Disc Ceramic, 0.1 µf, 50V	901410104	Sprague	33C41	*
C2	CAPACITOR, Vert. Mounting, Plastic Encased, 22 µf, 25V, Normal Position	903300226	Nashville Elect.	16-375BP22-25S85 NP	*
C3	Same as C2				
C4	Same as C1				
C5	Same as C1				
CR1	DIODE, S10G, Silicon	910500010	Transitron	S10G	*
R1	RESISTOR, Fixed Composition, 220K, ± 5%, 1/4W	906900224	Speer		*
R2	RESISTOR, Fixed Composition, 3300Ω, ±5%, 1/4W	906900332	Speer		*
R3	RESISTOR, Fixed Composition, 6800Ω, ±5%, 1/4W	906900682	Speer		*
R4	RESISTOR, Fixed Composition, 1200Ω, ±5%, 1/4W	906900122	Speer		*
R5	RESISTOR, Fixed Composition, 1500Ω, ±5%, 1/4W	906900152	Speer		*
R6	RESISTOR, Fixed Composition, 150Ω, ±5%, 1/4W	906900151	Speer		*
R7	RESISTOR, Fixed Composition, 18K, ±5%, 1/4W	906900183	Speer		*
R8	RES4STOR, Fixed Composition, 8200Ω, ±5%, 1/4W	906900822	Speer		*

*Previously Accounted For

MODEL 128A

Section V

REPLACEABLE PARTS LIST

Schem. Ref. No.	Description	Sierra Stock No.	Mfr.	Dwg. or Mfr. No.	Tot. Quan.
Q1	TRANSISTOR, NPN	910300024	Fairchild	2N706B	*
Q2	TRANSISTOR, NPN	910300022	Motorola	2N706A	*
Q3	Same as Q2				
XQ1	SOCKET, Trans. 3 Pin	914200036	Grayhill	22-16-3	*
XQ2	Same as XQ1				
XQ3	Same as XQ1				
	B- FILTER - B02003200				
C1	CAPACITOR, Disc Ceramic, .01 μ f, 150V	901440103	Centralab	DDM-103	*
C2	Same as C1				
C3	CAPACITOR, Vert. Mtg. Plastic Encased, 22 μ f, 25V, Normal Position	903300226	Nashville Elect.	16-375BP22-25S85 NP	*
C4	CAPACITOR, Disc Ceramic, 0.1 μ f, 50V	901410104	Sprague	33C41	*
C5	Same as C1				
L1	INDUCTOR, Fixed 3.30 mh	909000116	J.W. Miller	70F333A1	*
L2	Same as L1				
L3	Same as L1				
L4	Same as L1				

*Previously Accounted For

MODEL 128PA

Section V

REPLACEABLE PARTS LIST

Note: Order replaceable parts through normal supply channels.

Schem. Ref. No.	Description	Sierra Stock No.	Mfr.	Dwg. or Mfr. No.	Tot. Quan.
L1	INDUCTOR, Micromin., 1.8 h	909000127	Miller	9230-26	1
P1	PLUG AND CABLE ASSEMBLY			B02045300	1
R1	RESISTOR, Fixed, Metal film, 600 ohm 1% 1/2W	907400179	Campbell	M-07	1
R2	RESISTOR, Fixed, Metal film, 135 ohm 1% 1/2W	907400180	Campbell	M-07	1
R3	RESISTOR, Fixed, Composition, 200 ohm, 5% 1/4W	906900221			1
R4	RESISTOR, Variable, Cermet, 200 ohm, 10% 1/8W	907900190	CTS	385PC 201A	1
S1	SWITCH, Slide, DP 3 position, miniature	911000028	Continental Wirt	G-128L	1
T1	TRANSFORMER		Sierra	SS-14782-1	1

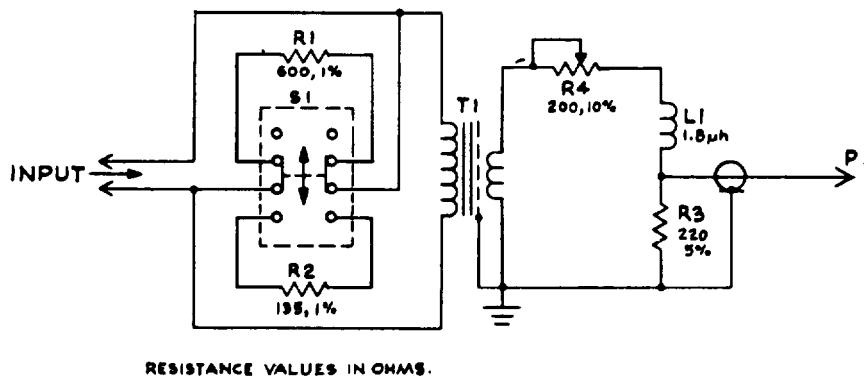

Figure A-2. Model 128-PA Balanced Probe Schematic Diagram

APPENDIX A
MODEL 128-PA
BALANCED PROBE
(AUXILIARY EQUIPMENT)

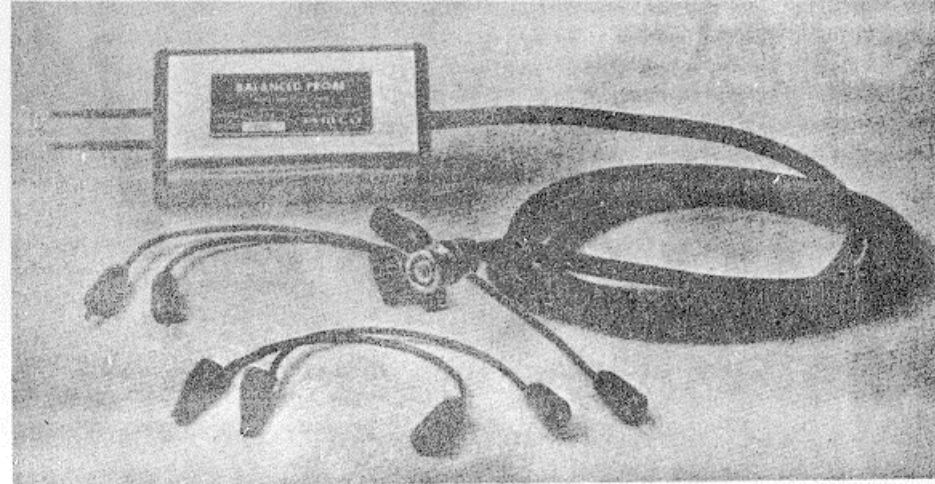

Figure A-1. Balanced Probe With Auxiliary Flexible Leads

The Model 128-PA Balanced Probe is an accessory to the Model 128A Frequency Selective Voltmeter with the purpose of providing the Voltmeter with a balanced input.

The Balanced Probe may be used in either the bridging mode or in the terminating mode with the choice of either a 135 ohm or c 600 ohm terminating resistance. A three position slide switch permits the selection of either mode and either of the two terminating resistances. A chart, attached to the probe body for convenient reference, lists the Probe switch settings along with the corresponding Voltmeter input settings. The Probe may also be used on unbalanced circuits, if desired, by grounding either probe tip.

The Probe circuitry is enclosed in a metal and plastic case and is fitted with a 5 foot coaxial cable terminated with a BNC connector for attachment to the 128A Voltmeter. The Probe tips are spaced 1/2 inch apart and are 1-1/2 inches long for convenient manipulation on high component density equipment.

Two sets of flexible extension test leads are furnished to provide maximum auxiliary use of the Probe. The test leads attach to the Probe tips and provide either pin plug or miniature alligator clip termination.

MODEL 128-PA

A-6.

SPECIFICATIONS

CIRCUIT IMPEDANCE	135 Ohms	600 Ohms
FREQUENCY RANGE	10 kc to 3.5 mc	10 kc to 1.5 mc
INSERTION LOSS	20 db \pm 0.25 db	20 db \pm 0.25 db
BRIDGING LOSS	0.1 db	0.2 db up to 620 kc 0.25 db up to 1.5 mc
INPUT IMPEDANCE		
Bridging Mode		
At 1 mc		13 K in parallel with 18 pf
At 3.5 mc		8 K in parallel with 20 pf
Terminating Mode		
135 Ohm		Reflection coefficient less than 2%
600 Ohm		Reflection coefficient less than 4%
MAXIMUM INPUT LEVEL		+20 dbm
MINIMUM INPUT LEVEL		-90 dbm
DIMENSIONS		
Width		2.2 inches
Thickness		1.3 inches
Length		
Body		4.2 inches
Overall		5.7 inches
Probe Tip Spacing		0.5 inches
Coaxial Cable Length		5 feet
AUXILIARY FLEXIBLE LEADS		
Length		6 inches
2-Red, 1-Brown		Pin jack on one end, pin plug on other
2-Red		Pin jack on one end, miniature alligator clips on other

MODEL 128-MA

APPENDIX B
EXPANDED SCALE METER
MODEL 128-MA

AUXILIARY EQUIPMENT

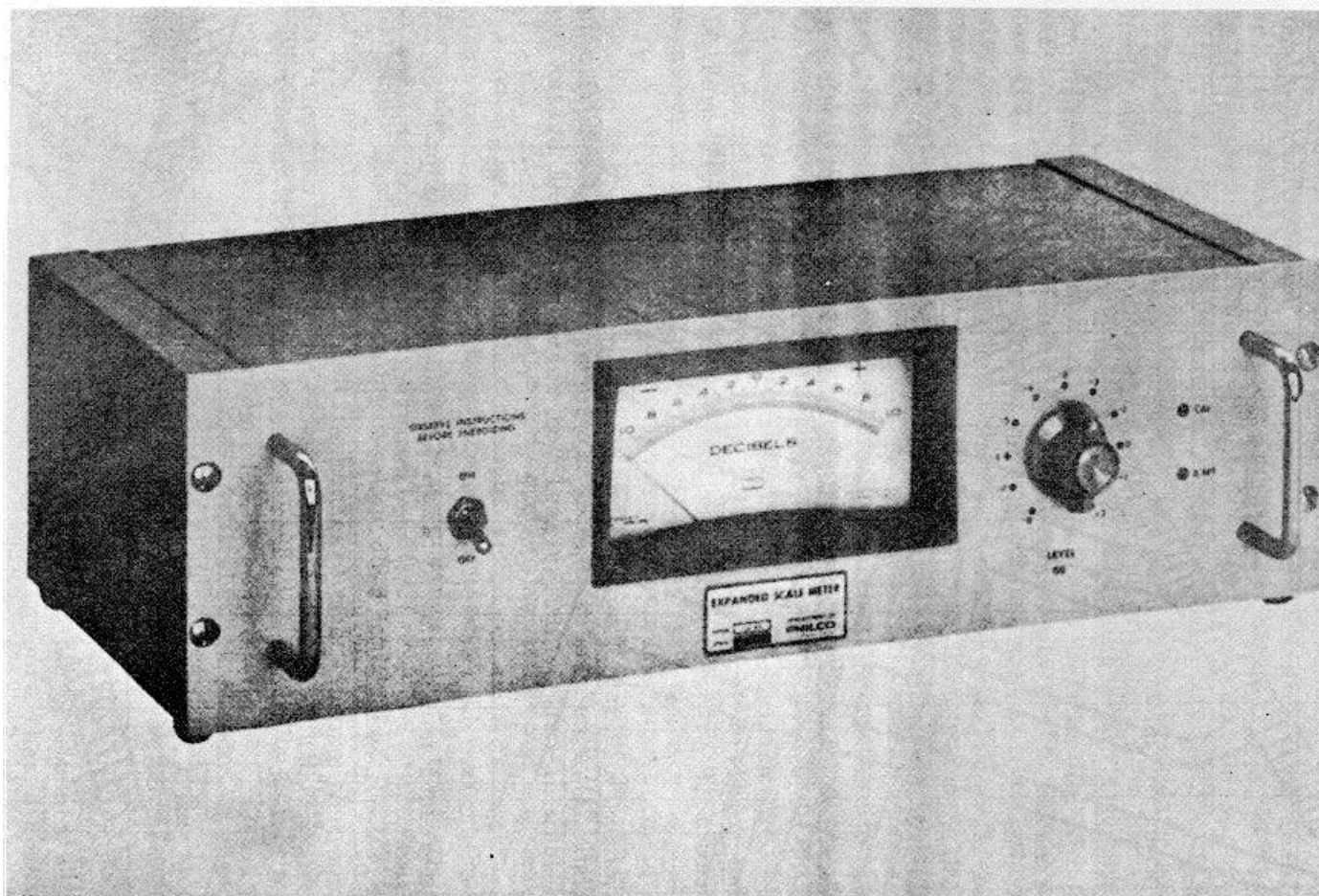

Figure B-1. Model 128-MA Expanded Scale Meter.

MODEL 128-MA

SECTION I

GENERAL

A. PURPOSE

The Sierra Model 128-MA Expanded Scale Meter is made for use with Sierra Model 128A Frequency Selective Voltmeter to provide an expanded full scale reading of plus or minus one db readable to 0.01 db. In use the 128-MA is plugged into the Frequency Selective Voltmeter Recorder jack.

B. DESCRIPTION

Major scale divisions of the large, 6 inch, zero db center scale, meter of the 128-MA, are 0.1 db and subdivisions are at 0.02 db intervals so that it is readily possible to read relative level variations as small as 0.01 db. The instrument is equipped with a level control having a range of 10 db in one db steps, so that the Expanded Scale Meter is not limited to one specific two db interval. This makes it possible to use the Expanded Scale Meter at any level between -8 db and +2 db on the Model 128A Voltmeter. Since the 128A can always be made to read in that interval by means of its own 10 db step level control, the Expanded Scale Meter may be used at any level within the range of the 128A Voltmeter. Any tracking error in the 128A is considerably reduced when readings are taken with the 128-MA.

The instrument is mounted on a 5 1/4 inch panel, equal in width to the Model 128A. It can be used either as a rack-mount or as a bench-mount instrument. Sheet metal end pieces equipped with rubber feet fill out both ends for bench use. A 3-3/4 foot length of interconnecting cable allows the 128-MA to be conveniently located a short distance from the 128A Voltmeter.

The internal power source is a single cell, size D, zinc-carbon battery. The useable voltage range is between 1.6 and 1.35 volts. The current drain is about 75 microamperes.

The battery should be replaced every six months, or sooner if the voltage drops below the minimum of 1.35 volts.

The 128-MA must be calibrated to the particular Model 128A with which it is to be used. When ordered together the two instruments are calibrated together at the factory. In any case, calibration procedure as given in Section II, A2 should be carried out at regular intervals.

MODEL 128-MA

Section I

C. SPECIFICATIONS

LEVEL RANGE	+3 db to -9 db, relative to each Model 128A attenuator position
METER	
Range	2 db total
Marking	-1 db to +1 db
Divisions	0. 1 main divisions 0.02 subdivisions
Resolution	0.01 db
LEVEL SELECTOR	
Range	10 db
Marking	+2 db to -8 db
Divisions	1 db
IMPEDANCE	1200 ohms
POWER SUPPLY	
Type	Internal Battery 1 size D cell
Current Drain	75 microamperes
LENGTH OF CABLE	3-3/4 feet
CONNECTOR	Telephone plug
MOUNTING	Rack or bench
DIMENSIONS	
Width	19 inches
Height	5-1/2 inches
Depth	7-3/8 inches
Depth (including handles)	9 inches
WEIGHT	9 pounds

MODEL 128-MA

Section II

SECTION II

OPERATION

Since the 128A is a very sensitive instrument and subject to damage by overload it is important that the following operating instructions be carefully read before energizing the meter.

A. PRELIMINARY CHECKS AND CALIBRATION

The power switch should be left in the OFF position, except when readings are to be made.

1. Polarity

When connecting the 128-MA to a Model 128A Frequency Selective Voltmeter with which it has not previously been used, the RECORDER jack polarity should be checked as follows:

- a. Plug the 128-MA into the 128A Voltmeter RECORDER jack. (128-MA power switch OFF.)
- b. Turn the 128A Voltmeter Attenuator switch to CAL and adjust for a 128A meter reading of about 0 db.

c. Unscrew the plastic handle of the 128-MA interconnecting cable plug, leave plug in position in the RECORDER jack and check relative polarity of terminals. The white wire, plug sleeve connection, should be positive with regard to the block wire, plug tip connection.

2. Calibration

The Model 128-MA Expanded Scale Meter (ESM) must be calibrated to the 128A Frequency Selective Voltmeter (FSVM) with which it is to be used. Calibration procedure should be carried out at regular intervals.

- a. Equipment Required (Instruments listed or their equivalent)

Multimeter	Simpson 260
DC Voltmeter	HP 413
Signal Generator	HP 606A
600 Ohm Attenuator	Daven VT-795-G

MODEL 128-MA

Section II

Test Fixture .	1.5V zinc-carbon battery with 60K resistor (two 120K resistors in parallel)soldered to it.
Resistor	560 ohm, 5%, 1/4W
Clip Leads (2)	

Sierra Model 128A Frequency Selective Voltmeter to which Model 128-MA is to be calibrated.

CAUTION: The 128-MA power switch must be kept in the OFF position at all times unless specifically instructed otherwise.

b. Resistance Check (All except step (3) should be omitted when routine calibration is performed)

(1) Adjust R21, R23-R30 and R39 of 128-MA to mid-range (7-1/2 turns from either end)

(2) Turn CAL control on front panel of the 128-MA six full turns clockwise from end point.

(3) Check the resistance between the tip and the sleeve of the 128-MA plug with an ohmmeter for all positions of the LEVEL attenuator of the 128-MA. The resistance must be exactly the same for all positions of the LEVEL attenuator control. (Resistance value may be anywhere between 1000 and 1200 ohm. The important thing is that the resistance be exactly the same for each setting of the LEVEL attenuator control.) If resistance is different in one or more positions, return to factory for repair.

c. Meter Bridge Balance

(1) Set the 128-MA LEVEL control to -8 db. Remove internal battery from the 128-MA and connect Test Fixture (1.5V battery in series with 60K resistor) in its place, but with reverse polarity. Use the two clip leads.

(2) Switch the 128-MA to ON. This will bring the meter slowly to about full scale.

(3) Set the HP 413 to its most sensitive range in EXPANDED position. Short leads and zero meter.

(4) Connect the HP 413 to test points TP1 and TP2. See Figure B-2.

MODEL 128-MA

Section II

- (5) Adjust potentiometer R36 for zero reading on the HP 413.
- (6) Turn the switch on the 128-MA to OFF. Remove test fixture and replace the internal battery.

NOTE: Once the above adjustment is made either at the factory or in the meter calibration shop, it should only need checking at infrequent intervals.

d. Calibration Procedure

(1) Test Setup

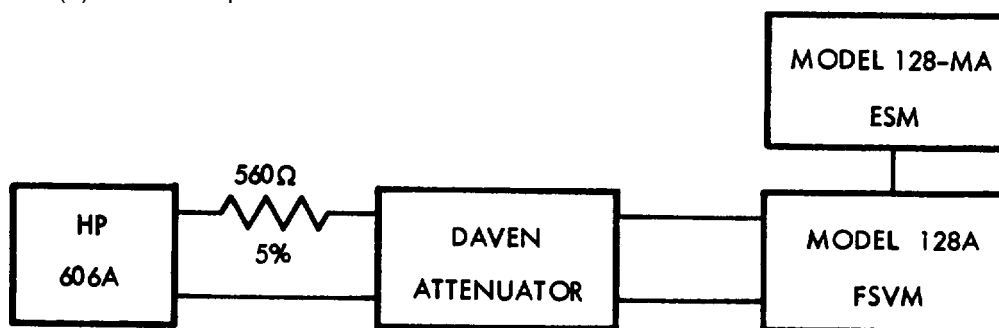

(2) Allow at least one hour for warmup of equipment then set the HP 606A to 100 kc and output level to about 0 dbm. Set Daven attenuator to 22.0 db. Set the 128A FSVM to -20 db, TERM, 600 Ohms. Adjust the level of the HP 606A so that the 128A reads close to 0 db.

(3) Plus the 128-MA into the 128A, then set the 128A to read exactly 0 db using the CAL control.

(4) Set the 128-MA LEVEL control to 0 db, turn the switch to ON and adjust to read zero by adjusting the O-SET control on the front panel.

(5) Remove 1 db of attenuation (switch the Daven attenuator from 2 db to 1 db) and note position at which 128-MA meter needle comes to rest.

(6) Add 1 db of attenuation to the circuit (reset Daven attenuator from 1 db to 2 db), then adjust CAL control as follows: If meter came to rest short of +1 db in the preceding step turn CAL control clockwise until meter moves about five times as much as it was short of +1 db. Turn CAL counterclockwise if needle of meter was above +1 db.

(7) Very accurately reset meter to 0 db with the O-SET control. Check that 128A is exactly on 0 db when making this setting.

MODEL 128-MA

Section II

(8) Repeat steps (5), (6) and (7) as necessary until the 128-MA accurately covers the 0 to 1 db range when 1 db is removed from the attenuator. When this adjustment has been accurately made, do not again change the O-SET or CAL adjustments for remainder of calibration procedure.

(9) With the 128A and the 128-MA exactly set to 0 db, increase the attenuation 1 db (set Daven to 3 db). 128-MA should read $-1 \text{ db} \pm 0.02 \text{ db}$.

(10) Reset the Daven attenuator to 2 db. Then turn the 128-MA LEVEL control to -1 db and the Daven attenuator to 3 db, both at the same time. When the 128-MA meter has come to rest, adjust R23 for a reading of exactly 0 db.

(11) Set the 128-MA LEVEL control to -2 db and the Daven attenuator to 4 db at the same time. When the meter has come to rest adjust R24 for a reading of exactly 0 db. In the same manner take the 128-MA and the Daven attenuator down in 1 db steps to -8 db on the 128-MA, adjusting resistors R25-R30 for 0 db reading. Check that the 128A remains at exactly 0 db at each step. Use 128A CAL control to adjust if necessary.

(12) Return the 128-MA to 0 db and the Daven attenuator to 2 db. Switch both controls at the same time. Then switch the 128-MA LEVEL control to +1 db and the Daven attenuator to 1 db. Adjust R21 for a 0 db reading on the 128-MA. Follow same procedure for +2 db, adjusting R39.

(13) Turn 128-MA power switch to OFF before unplugging from the 128A.

NOTE: The following Speed-Up technique may be used: Whenever the 128-MA reading is to be changed 1 db, the movement of the meter may be speeded up by setting the LEVEL control 1 db farther than required and watching meter needle movement. When needle approaches the expected point, switch the LEVEL control rapidly back to the proper position.

(14) After the calibration adjustment is completed the O-SET control may be adjusted without affecting the calibration. Due to aging of the battery it will be necessary, occasionally, to readjust the O-SET, steps d2 through d4. This will not affect the calibration.

NOTE: For 128-MA O-SET adjustment only the 128A Gain Reference Oscillator (128A attenuator switch in CAL position) may be used to set the 128A meter to exactly 0 db in place of an external signal generator.

MODEL 128-MA

It may be noticed that after the 128-MA is calibrated as above, if the signal is reduced to -8 db on the 128A meter (signal level change on the 128A followed by switching the 128-MA LEVEL control down to -8 db as the signal level is lowered) that the -8 db signal level on the 128A meter does not exactly correspond to 0 db on the 128-MA meter. The extreme of variation should be less than .3 db. This is due to the allowable tracking error of the 128A meter scale. In this case the 0 db setting of the 128-MA will accurately represent -8 db. Points between -8 db and -2 db will show a relatively smaller tracking error. The +2 db point should be almost exact.

B. OPERATIONAL PROCEDURE

The power switch should be kept in the OFF position except when readings are to be made.

Assuming that the 128-MA has been properly calibrated with the 128A Voltmeter with which it is to be used, is plugged into the 128A and the power switch is OFF, follow the procedure given below:

1. Tune the 128A Voltmeter to the desired signal and set the Input Attenuator so that the meter reads between -8 db and +2 db.
2. Set the LEVEL control of the 128-MA to the position that is closest to the 128A meter reading. For example: A signal reads between -3 db and -2 db, but is closest to -2 db on the 128A meter. Set the 128-MA LEVEL control to -2 db. Zero db on the 128-MA now corresponds to -2 db, and the 128-MA meter covers the range of -3 db to -1 db.
3. Switch the 128-MA to ON and take reading.
4. The meter of the 128-MA may be kept on-scale with large excursions of signal level in the 128A, within the 10 db range of the 128-MA LEVEL control, by following the 128A meter reading in db with the LEVEL control of the 128-MA.
5. When a change in level beyond the range of the 128-MA level control is to be made:
 - a. Turn the 128-MA power switch to OFF.
 - b. Make readjustment for signal with the 128A Attenuator until the 128A meter reads between -8 db and +2 db.
 - c. Set the 128-MA LEVEL control to the position that is closest to the 128A meter reading (see paragraph 2. above).

MODEL 128-MA

d. Turn 128-MA power switch to ON and make reading.

6. Check the zero setting of the 128-MA occasionally, paragraph A.2. d2 through d4 to correct for battery aging.

Always turn the 128-MA power switch to OFF before unplugging from the 128A.

The signal input to the 128A Voltmeter should never be interrupted, or abruptly changed in level as long as the 128-MA is plugged into the 128A and is turned ON. Switch OFF the 128-MA before such changes are made.

Switching OFF the 128-MA will not change the meter reading of the 128A Voltmeter as long as the 128-MA is left plugged in, so the Voltmeter may be used in the normal manner without unplugging the 128-MA.

C. OVERLOAD CONSIDERATIONS

The 128-MA Expanded Scale Meter is designed to take from 5 to 10 times overload without damage.

If the meter is switched on without being plugged into the 128A, or if the signal being measured is switched off while the 128-MA is plugged in and operating, the meter pointer will be deflected violently to the left by the battery "bucking" voltage. This is an overload of approximately 3.6 times and should not damage the meter coil, although the pointer may eventually become bent.

If the signal level is increased 10 db by switching the 128A Voltmeter Attenuator of the signal generator level, without turning OFF the 128-MA, the meter will be overloaded about ten times and quite possible may be camaged.

If the signal level is increased 20 db by switching either the 128A Voltmeter attenuator or the signal generator level without turning OFF the 128-MA, meter damage is likely to occur.

Habitual care in adjusting signal levels to be measured and the practice of keeping the 128-MA switch OFF except when making readings, can prevent serious overloading of the instrument.

MODEL 128-MA

**SECTION III
THEORY OF OPERATION**

The 128-MA Expanded Scale Meter is built around a balanced bridge circuit. The arms of the bridge are R31, R32, R33 and the Meter M1, with its calibrating resistor R36. (Refer to the Schematic Diagram)

Current from the 128A Voltmeter is applied between points A and B (see schematic) and the meter "bucking" current is applied between points P and Q.

Resistors R1 through R10 are the multiplier resistors in parallel with points A and B. Resistors R11 through R20 are the impedance balancing resistors in series with the bridge points A and B. These resistors are selected by the LEVEL switch S1A and SIC.

The meter "bucking" battery is connected between points P and Q in series with the current limiting and calibrating resistors R35 and R37. This "bucking" current connection to the balanced bridge circuit prevents the battery current from flowing in the 128A output circuit. Also connected between P and Q are the resistors R21 through R30 and R39, selected by LEVEL switch S1E. These resistors provide a fine adjustment for the "bucking" current through the meter for every setting of the LEVEL control to provide improved linearity.

The purpose of the "bucking" current is to make it possible to measure the difference between two fairly large currents with a very sensitive meter. The difference at the zero db point on the meter is 5 microamperes and a difference of 0 to 10 microamperes covers a two db range, although the currents actually flowing from the battery and the 128A are much larger. Since the bucking current remains constant, the meter responds to any change in current from the 128A and is calibrated to show this change in db.

When the 128-MA power switch is turned to the OFF position the meter is switched out of the circuit and a resistance equal to the meter internal resistance is switched in. Thus the 128A sees exactly the same resistance whether the 128-MA is ON or OFF as long as it is left plugged into the 128A. In addition, in the OFF position, the switch puts a shunt across the meter and disconnects the internal battery.

R38 is the front panel CAL adjustment and R37 is the O-SET adjustment. R36 is an internal, factory set adjustment to compensate for slight differences in meter internal resistances.

MODEL 128-MA

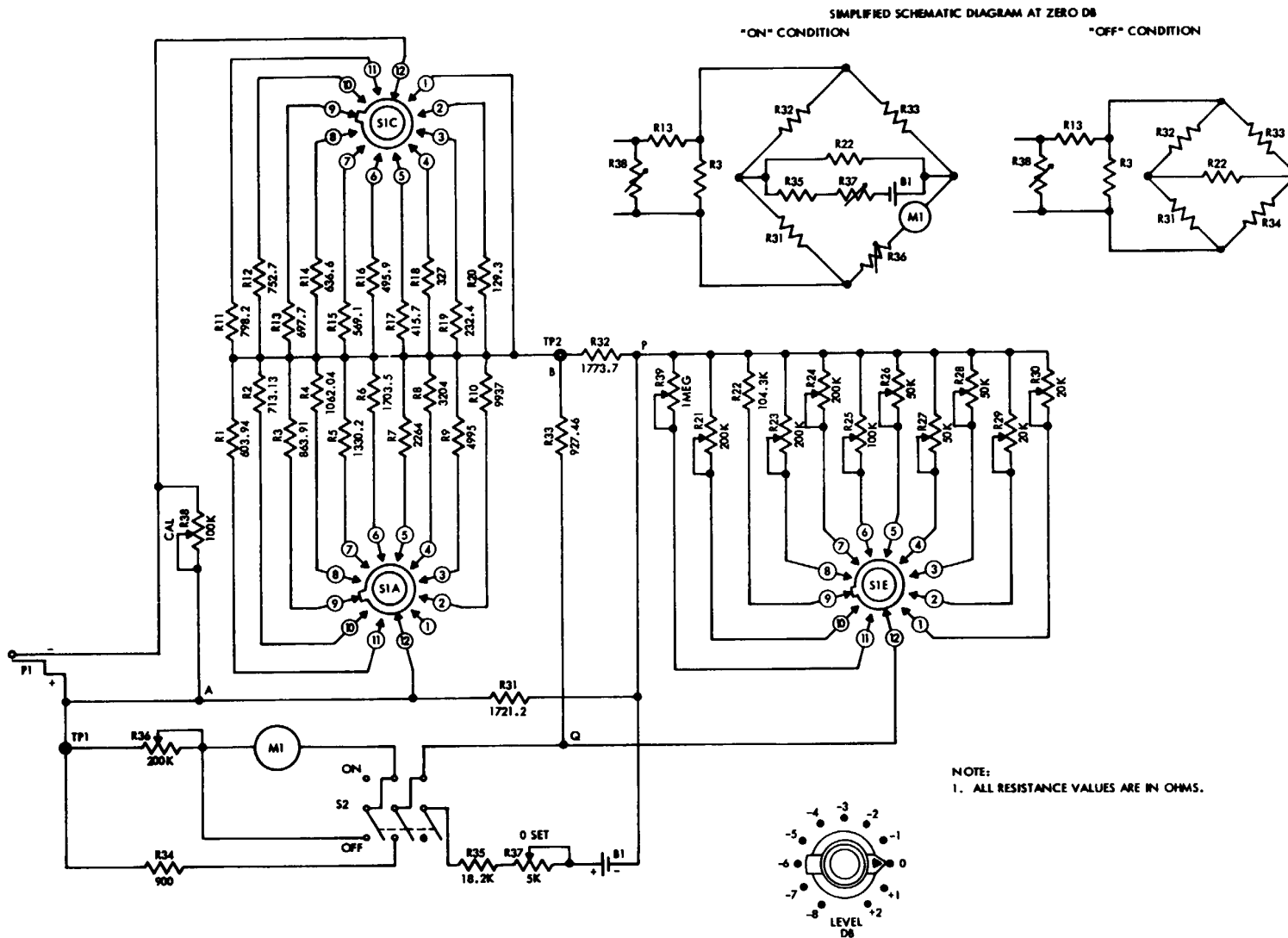

Figure B-2. Model 128-Model Expanded Scale Meter Schematic Diagram

MODEL 128-MA

**SECTION IV
REPLACEABLE PARTS LIST**

PARTS REPLACEMENT

Standard components have been used in this instrument. Whenever possible, identify parts by their Sierra stock numbers. Order replacement parts through normal supply channels.

When ordering parts always include:

1. Sierra Stock Number.
2. Circuit Reference and Commercial Description.
3. Name, Model and Serial Number of the Instrument.

Parts for this instrument, or further service information may be obtained from:

MODEL 128-MA

REPLACEABLE PARTS LIST

Schem. Ref. No.	Description	Sierra Stock No.	Mfr.	Dwg. or Mfr. No.	Tot. Quan.
B1	BATTERY, D-Cell, Zinc-Carbon	918500006	Mallory		1
M1	METER, Taut Bond, 10 microamp	911800082	A.P.I. 1602	A02024700	1
P1	PLUG-CORD Assembly		Sierra	B02034200	1
R1	RESISTOR, 603.94Ω Fixed WW, 0.05% 1/4W	906100034	Vidar	255A	1
R2	RESISTOR, 713.13Ω Fixed WW, 0.05% 1/4W	906100035	Vidar	255A	1
R3	RESISTOR, 863.91Ω Fixed WW, 0.05% 1/4W	906100036	Vidar	255A	1
R4	RESISTOR, 1062.04Ω Fixed WW, 0.05% 1/4W	906100037	Vidar	255A	1
R5	RESISTOR, 1330.2Ω Fixed WW, 0.05% 1/4W	906100038	Vidar	255A	1
R6	RESISTOR, 1703.5Ω Fixed WW, 0.05% 1/4W	906100039	Vidar	255A	1
R7	RESISTOR, 2264.0Ω Fixed WW, 0.05% 1/4W	906100040	Vidar	255A	1
R8	RESISTOR, 3204Ω Fixed WW, O. 1% 1/4W	906100041	Vidar	255A	1
R9	RESISTOR, 4995Ω Fixed WW, 0.1% 1/4W	906100042	Vidar	255A	1
R10	RESISTOR, 9937Ω Fixed WW, 0.2% 1/4W	906100043	Vidar	255A	1
R11	RESISTOR, 798.2Ω Fixed WW, 0.2% 1/4W	906100044	Vidar	255A	1
R12	RESISTOR, 752.7Ω Fixed WW, 0.2% 1/4W	906100045	Vidar	255A	1
R13	RESISTOR, 697.7Ω Fixed WW, 0.2% 1/4W	906100046	Vidar	255A	1
R14	RESISTOR, 636.6Ω Fixed WW, 0.2% 1/4W	906100047	Vidar	255A	1
R15	RESISTOR, 569.1Ω Fixed WW, 0.2% 1/4W	906100048	Vidar	255A	1
R16	RESISTOR, 495.9Ω Fixed WW, 0.2% 1/4W	906100049	Vidar	255A	1
R17	RESISTOR, 415.7Ω Fixed WW, 0.2% 1/4W	906100050	Vidar	255A	1
R18	RESISTOR, 327.0Ω Fixed WW, 0.5% 1/4W	906100051	Vidar	255A	1
R19	RESISTOR, 232.4Ω Fixed WW, 0.5% 1/4W	906100052	Vidar	255A	1
R20	RESISTOR, 129.3Ω Fixed WW, 1.0% 1/4W	906100053	Vidar	255A	1
R21	RESISTOR, 200K, Variable, ±20%, .2W, 15 Turn	907900202	Bourns	3068P-1-204	3
R22	RESISTOR, 104.3K Fixed WW, 1.0% 1/4W	906100055	Vidar	255A	1
R23	Same as R21				
R24	Same as R21				
R25	RESISTOR, 100K, Variable, ±20%, .2W, 15 Turn	907900203	Bourns	3068P-1-104	1
R26	RESISTOR, 50K, Variable, ±20%, .2W, 15 Turn	907900204	Bourns	3068P-1-503	3
R27	Same as R26				
R28	Same as R26				
R29	RESISTOR, 20K, Variable, ±10%, .5W, 15 Turn	907900205	Bourns	3067P-1-203	2
R30	Same as R29				
R31	RESISTOR, 1721.2Ω Fixed WW, 0.05% 1/4W	906100064	Vidar	255A	1
R32	RESISTOR, 1773.7Ω Fixed WW, 0.05% 1/4W	906100065	Vidar	255A	1
R33	RESISTOR, 927.46Ω Fixed WW, 0.05% 1/4W	906100066	Vidar	255A	1
R34	RESISTOR, 900.00Ω Fixed WW, 0.05% 1/4W	906100067	Vidar	255A	1
R35	RESISTOR, 18.2K Fixed WW, 1.0% 1/4W	906100068	Vidar	255A	1
R36	RESISTOR, 200Ω Variable, 1W, 10%	907900192	Spectrol	74-2-1-201	1
R37	RESISTOR, 5KΩ Variable, 1W, 10%	907900193	Spectrol	74-2-1-502	1
R38	RESISTOR, 100KΩ Variable, 1W, 10%	907900194	Spectrol	74-2-1-104	1
R39	RESISTOR, 1 Meg, Variable, ±20%, .2W, 15 Turns	907900206	Bourns	3068P-1-105	1
S1	SWITCH, Rotary	911200109	Centralab	A02039000	1
S2	SWITCH, Toggle	911000029	A H & H		1

UNIVERSAL SPEAKER KIT

APPENDIX C
UNIVERSAL SPEAKER KIT

AUXILIARY EQUIPMENT

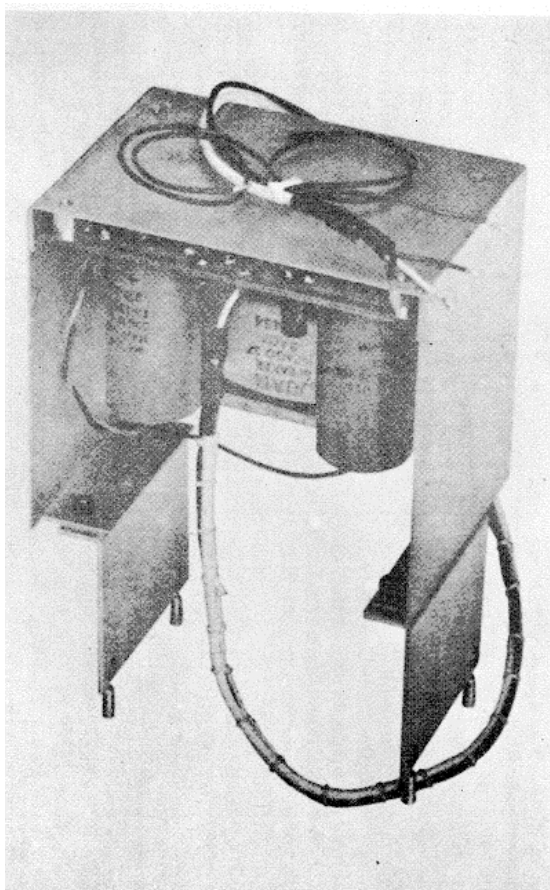

Figure C-1. Speaker Assembly With Model 125/126 Brackets

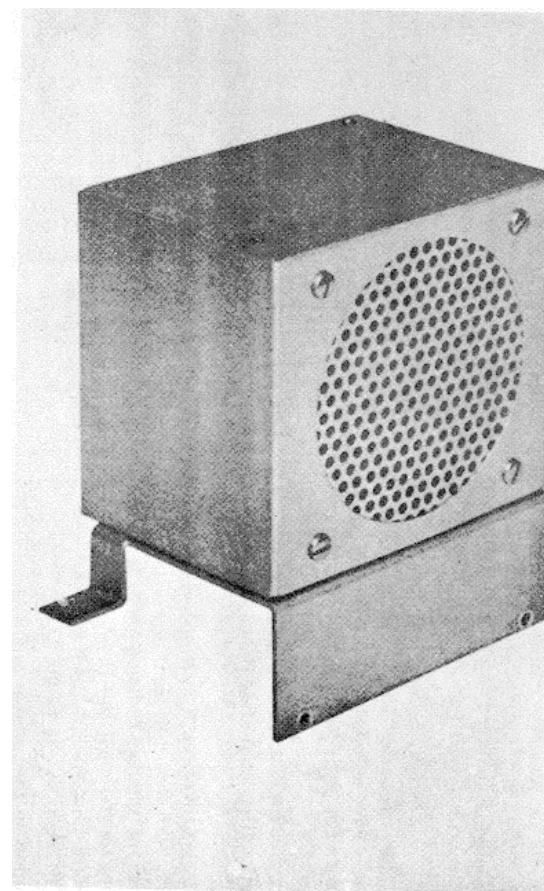

Figure C-2. Speaker Assembly With Model 128 Brackets

UNIVERSAL SPEAKER KIT

UNIVERSAL SPEAKER KIT

DESCRIPTION

The Sierra Universal Speaker Kit is made for use with all series and versions of the Sierra Models 125, 126 and 128 Frequency Selective Voltmeters. Installation of the Kit provides loud speaker monitoring of the audio modulation on the carrier signal being measured.

The Kit is made up of an audio amplifier and speaker mounted in a speaker case, a connecting cable and panel jack, and the required mounting brackets and hardware.

The three transistor amplifier, consisting of a driver stage and push-pull output stage, furnishes sufficient power to provide adequate speaker volume. Output level to either the speaker or headphones is controlled by the Voltmeter Audio Gain control. Power for the amplifier is taken from the Voltmeter, either through a dropping resistor from the power supply of the Model 128, or through a voltage doubling rectifier from the filament supply of the Model 125 or 126. The rectifier and dropping resistor are mounted on the speaker audio circuit board. The jack furnished with the kit, when installed to replace the Phones jack originally in the Voltmeter, switches off the speaker whenever headphones are plugged into the Voltmeter Phones jack.

SPECIFICATIONS

FREQUENCY RANGE	300 cps to 5 kc
Installed In Voltmeter	300 cps to 2.5 kc
FREQUENCY RESPONSE	±1 db
INPUT	2 volts p-p maximum
OUTPUT	0.25 watts undistorted
POWER REQUIREMENTS	
From Models 125, 126	6.3 volts AC, 120 ma, 50-1000 cps
From Model 128	-24 volts DC, 45 ma

UNIVERSAL SPEAKER KIT**SPECIFICATIONS (continued)**

DIMENSIONS (without brackets)	
Height	3-5/8 inches
Width	4 inches
Depth	2-7/8 inches
WEIGHT (without brackets)	14 ounces
SIERRA PART NO.	802074000

INSTALLATION PROCEDURE

1. Solder VIOLET wire to proper terminal on-Speaker Kit circuit board.

For Models 125 and 126 - to terminal marked 6.3 vac (fig. C-5).
 For Model 128 - to terminal marked -24 vdc. (fig. C-6).

2. Drill holes in chassis as required:

For Models 125 and 126, see Figure C-3.
 For Model 128, see Figure C-4.

Later production runs of all models will have the holes prepunched in the chassis.

3. Select brackets required and attach to speaker case:

For Models 125 and 126, see Figure C-1.
 For Model 128, see Figure C-2.

4. Fasten speaker case to chassis by means of brackets.

For Models 125 and 126, use number 6 Kep nuts on spade lugs.
 For Model 128, use number 4 machine screws and Kep nuts.

(In the -Y version of the Model 125, the "existing holes", Figure 3, are used to attach an under-chassis shield bracket. The screws in these holes are to be removed. The spade lugs on the speaker brackets replace them to hold both the speaker case and the under-chassis shield bracket.)

UNIVERSAL SPEAKER KIT

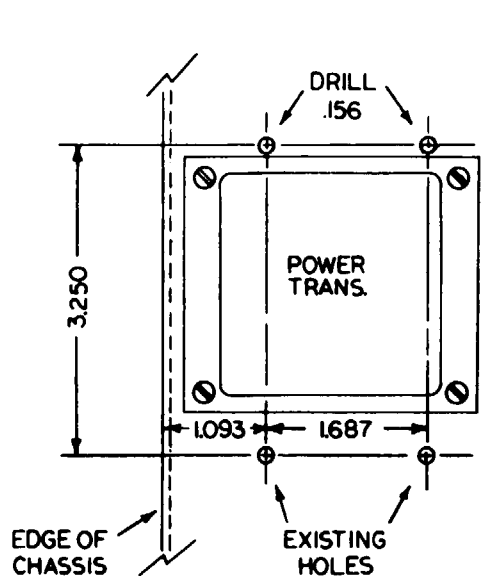

Figure C-3. Mounting Hole Location Model 125/126

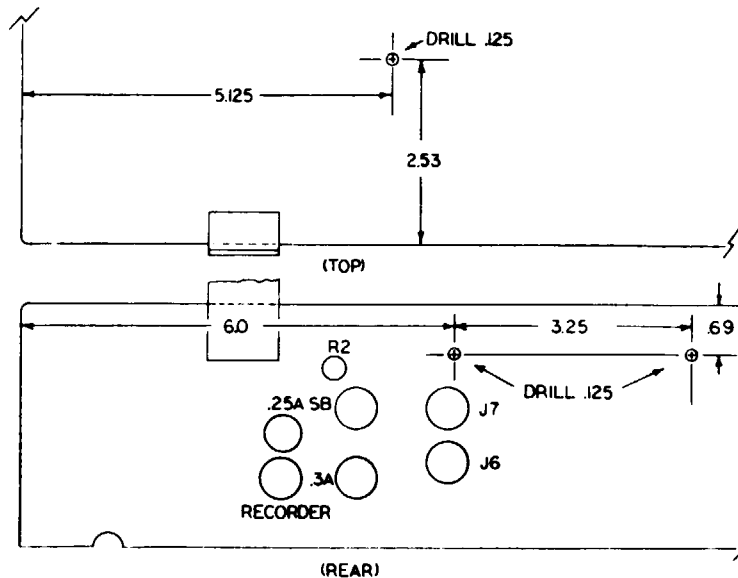

Figure C-4. Mounting Hole Location Model 128

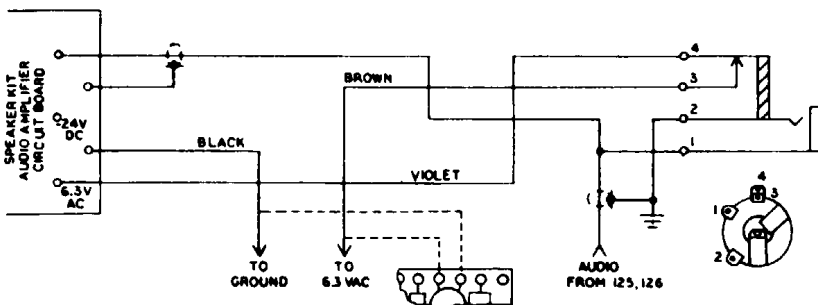

Figure C-5. Wiring Diagram Model 125/126

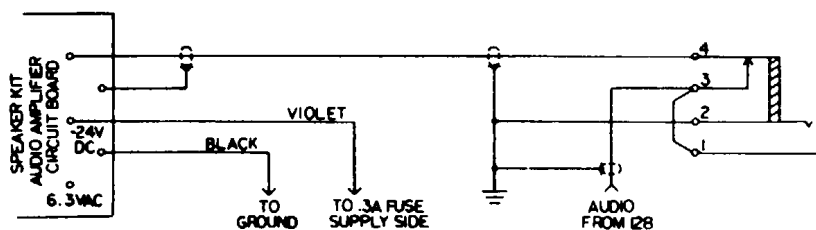

Figure C-6. Wiring Diagram Model 128

UNIVERSAL SPEAKER KIT

5. Run Speaker Kit cable into bottom of chassis.

In Models 125 and 126, lay cable in front of Mixer module cover and run down through space between RF tuning casting and chassis. Secure cable to projecting meter stud with plastic cable clamp and 6-32 Kep nut.

In Model 128, run cable down through large rubber grommet near center of chassis.

6. Disconnect leads from PHONES jack. Remove old jack and install the jack supplied with the kit. (Later production runs of all models will contain the new type jack as standard equipment.)

7. Reconnect audio leads and connect free end of speaker cable to jack according to wiring diagram. Connect Brown and Black leads to circuit board.

For Models 125 and 126 use Figure C-5. Lead length is such that wiring runs are direct.

For Model 128 use Figure C-6 and following procedures

- a. Remove shield cover from Audio circuit board of the 128 Voltmeter.
- b. Pull the Violet and Black wires out of the cable tie near the free end.
- c. Connect the Audio lead from the Model 128 Audio circuit board to jack terminal 1.
- d. Run the Audio lead of the speaker cable underneath the Model 128 Audio circuit board and connect to jack terminal 4. Connect shield and ground lead from Audio circuit board to jack terminal 2.
- e. Cut off the long free end of the Brown wire. Leave enough to make the jumper connection from terminal 1 to 3 on the jack, as indicated in Figure 6.
- f. Cut the Black lead to a convenient length and connect to one of the ground lugs near the power supply circuit board.
- g. Connect the free end of the Violet wire to the power supply side of the .3A fuse.
- h. Replace cover over Audio circuit board.

UNIVERSAL SPEAKER KIT
REPLACEABLE PARTS LIST

NOTE: Order replacement parts through normal supply channels.

Schem. Ref. No.	Description	Sierra Stock No.	Mfr.	Dwg. or Mfr. No.	Tot. Quan.
C1	CAPACITOR, 1 µf, 25V	903300105			1
C2	CAPACITOR, 500 µf, 25V	902210507	Malory	PTC	2
C3	Some as C2				
C4	CAPACITOR, 22 mf, 25V	903300226			1
CR1	DIODE	910500031		1N456	1
CR2	DIODE	910800008		DI 56	2
CR3	Same as CR2				
J1	CONNECTOR, Phone	914400014	Switchcraft	Littel Jak #13E	1
LS1	LOUDSPEAKER	921400002	Quam	3A07	1
Q1	TRANSISTOR, PNP	910300007	G.E.	2N404	1
Q2	TRANSISTOR, NPN	910300033	G.E.	7A31	2
R1	RESISTOR, 33K Ohm ±5% 1/4W	906900333	A.B.	CB	1
R2	RESISTOR, 10K Ohm ±5% 1/4W	906900103	A.B.	CB	1
R3	RESISTOR, 2.2K Ohm ±5% 1/4W	906900222	A.B.	CB	1
R4	RESISTOR, 22K Ohm ±5% 1/4W	906900223	A.B.	CB	2
R5	Same as R4				
R6	RESISTOR, 4.7 Ohm*10% 1/4W 907100470	A.B.	CB	2	
R7	Some a s R6				
R8	RESISTOR, 180 Ohm ±5% 1/2W	905000181	A.B.	EB	1
R9	RESISTOR, 3.3K ±5% 1/4W	906900332	A.B.	CB	1
T1	TRANSFORMER, Transistor P-P Input	910000072	UTC	SSO-8	1
T2	TRANSFORMER, Transistor P-P Output	910000074	UTC	0-22	1
	CABLE CLAMP	915300010			1

UNIVERSAL SPEAKER KIT

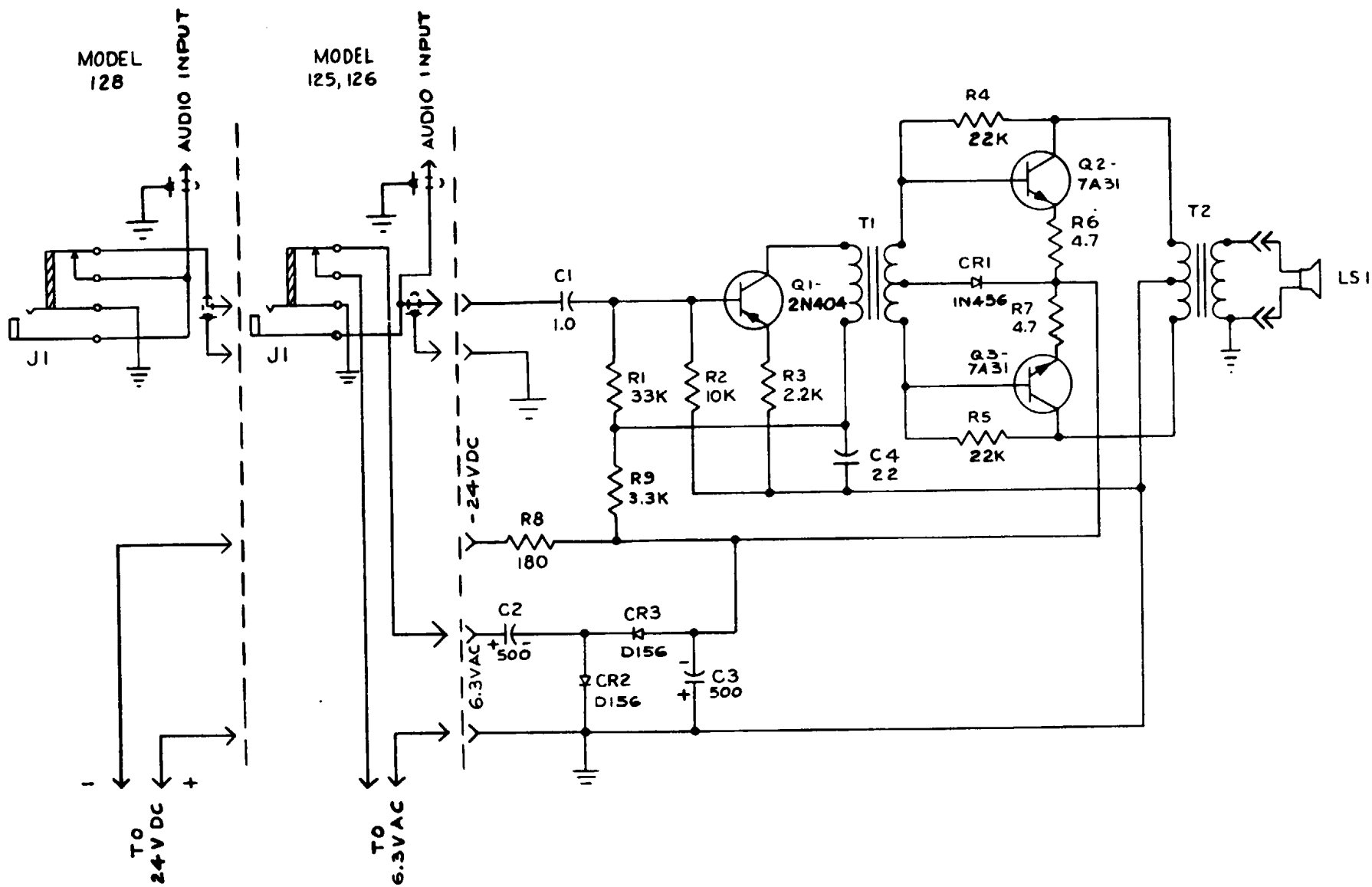

Figure C-7. Universal Speaker Kit Schematic Diagram

By Order of the Secretary of the Army:

HAROLD K. JOHNSON,
General, United States Army,
Chief of Staff.

Official:

KENNETH G. WICKHAM
Major General, United States Army,
The Adjutant General.

Distribution:

Active Army

USAMB (1)
SAAD (5)
TOAD (5)
LEAD (3)
Eighth USA (5)

USACDCEC (10)
USACDCCEA (1)
USACDCCEA:
Ft Huachuca (1)

NG: None.

USAR: None.

For explanation of abbreviations used, see AR 320-50.

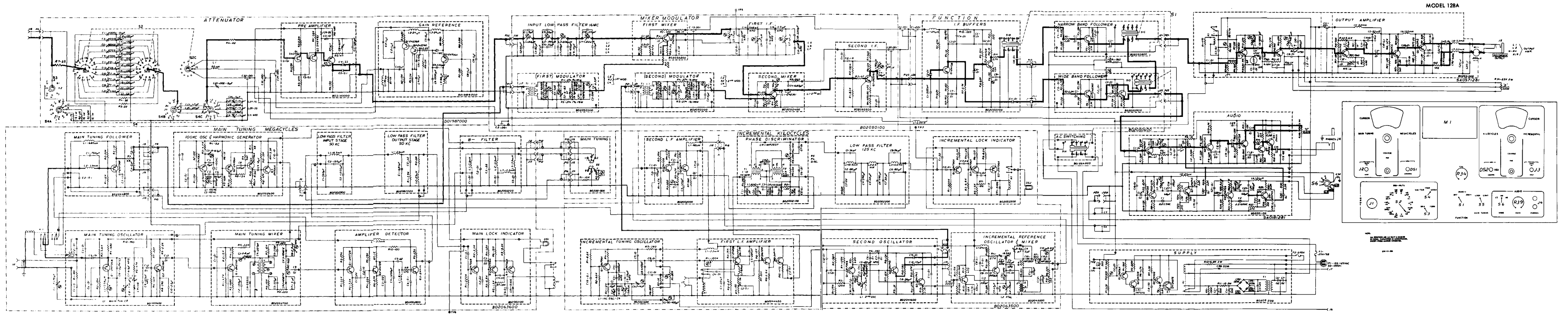

Figure 3-5. Model 128A Schematic Diagram

MODEL 128A

MODEL 128A

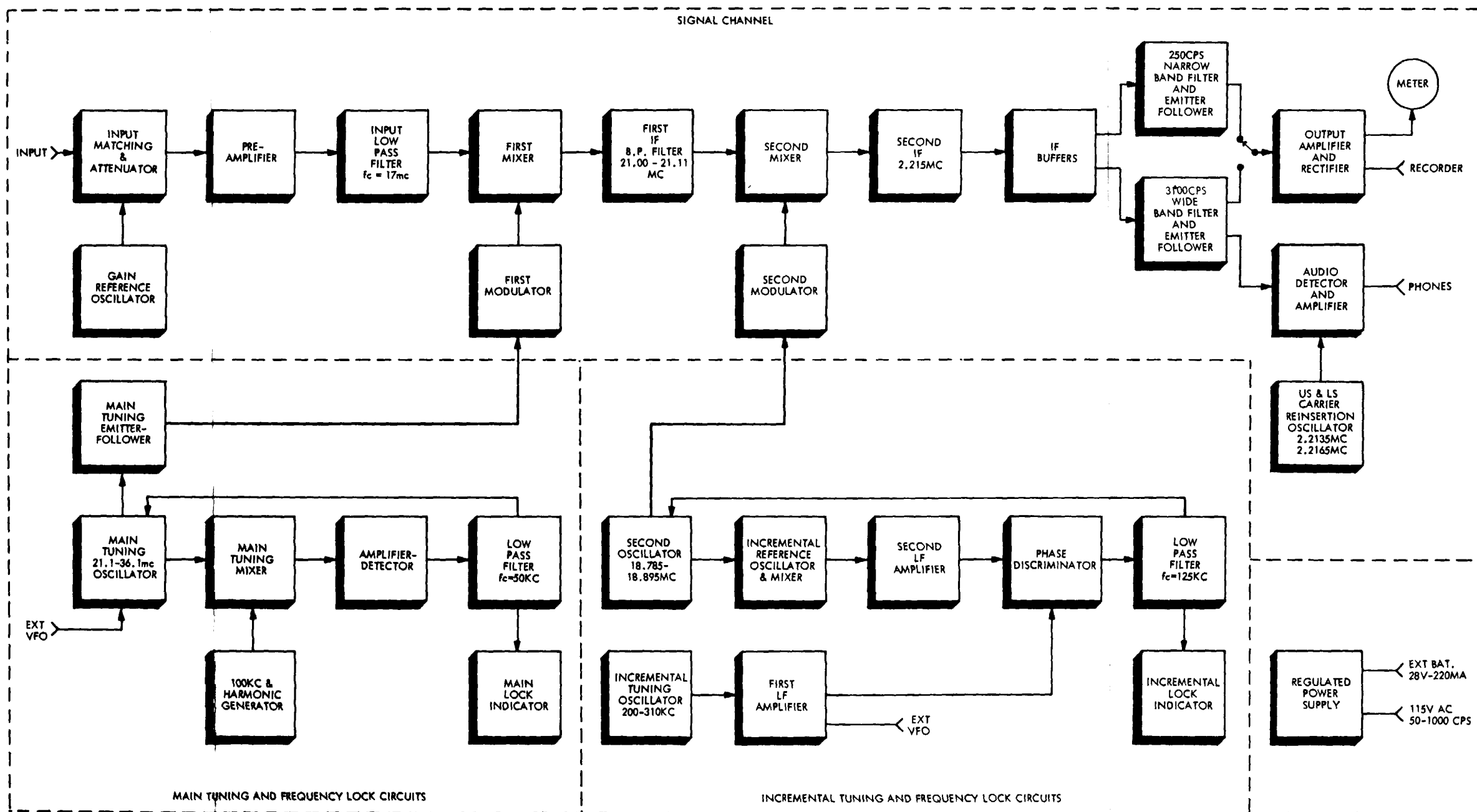

Figure 1-2. Model 128A Block Diagram

RECOMMENDED CHANGES TO EQUIPMENT TECHNICAL PUBLICATIONS



SOMETHING WRONG WITH THIS PUBLICATION?

THEN... JOT DOWN THE DOPE ABOUT IT ON THIS FORM, CAREFULLY TEAR IT OUT, FOLD IT AND DROP IT IN THE MAIL!

FROM: (PRINT YOUR UNIT'S COMPLETE ADDRESS)

DATE SENT

PUBLICATION NUMBER

PUBLICATION DATE

PUBLICATION TITLE

BE EXACT... PIN-POINT WHERE IT IS

PAGE NO.

PARA-GRAPH

FIGURE NO.

TABLE NO.

IN THIS SPACE TELL WHAT IS WRONG AND WHAT SHOULD BE DONE ABOUT IT:

TEAR ALONG PERFORATED LINE

PRINTED NAME, GRADE OR TITLE, AND TELEPHONE NUMBER

SIGN HERE:

DA FORM 2028-2
1 JUL 79

PREVIOUS EDITIONS ARE OBSOLETE.

P.S.—IF YOUR OUTFIT WANTS TO KNOW ABOUT YOUR RECOMMENDATION MAKE A CARBON COPY OF THIS AND GIVE IT TO YOUR HEADQUARTERS.

